

SMY133, SMY134, SMP133

Multifunctional Panel Meters

Operating Manual

Document revision	Release date	Valid for versions			
		hardware	bootloader	firmware	ENVIS
2.3	18.2.2022	2.6	4.3	4.0.31	2.0



LIST OF CONTENTS

1. GENERAL.....	6
1.1 Differences between SMY133, SMY134 and SMP133.....	7
2. INSTALLATION.....	8
2.1 Meaning of the symbols used on instrument.....	8
2.2 Physical.....	8
2.3 Instrument Connection.....	9
2.3.1 Safety Grounding (SMP133 only).....	9
2.3.2 Power Supply.....	10
2.3.3 Measured Voltages.....	10
2.3.4 Measured Currents.....	10
2.3.4.1 Current Type Current Inputs Instruments (Models „X/5A“, „X/100mA“).....	10
2.3.4.2 Voltage Type Current Inputs Instruments („X/333mV“ and „FLEX“ Models).....	11
2.3.5 Other Inputs/Outputs.....	12
3. COMMISSIONING.....	13
3.1 Setup.....	13
3.1.1 Measured Electrical Quantities Installation Setup.....	13
3.1.1.1 Setup Example.....	14
4. DETAILED DESCRIPTION.....	16
4.1 Basic Functions.....	16
4.2 Manipulation and Setting.....	16
4.2.1 Data Area – Status Bar - Toolbar.....	16
4.2.2 Main Menu.....	17
4.2.3 Main Data Group.....	17
4.2.3.1 Gauge Type Subscreen in the „Multiple“ Screen.....	19
4.2.3.2 „Clear“ Screen.....	21
4.2.3.3 Default Window.....	22
4.2.4 Actual & Average Data Groups.....	23
4.2.5 Electricity meter.....	23
4.2.6 Oscillograms.....	23
4.2.7 Phasor Diagram.....	23
4.2.8 Harmonics & THDs.....	24
4.2.9 Power Quality & Voltage Events.....	24
4.2.10 Ripple Control Signal.....	24
4.2.11 Instrument Settings (Parameters).....	25
4.2.11.1 Display Setting.....	25
4.2.11.2 Installation Setting.....	26
4.2.11.3 Remote Communication Setting.....	26
4.2.11.4 Clock Setting.....	26
4.2.11.5 Average Values Processing Setting.....	27
4.2.11.6 Embedded Electricity Meter Setting.....	27
4.2.11.7 Power Quality & Input/Output Setting.....	27

4.2.11.8	Ripple Control Signal Setting.....	27
4.2.12	Instrument Lock.....	27
4.2.12.1	Locking from the Instrument Panel.....	28
4.2.12.2	Unlocking from the Instrument Panel.....	28
4.2.12.3	Locking/Unlocking by the User Management.....	28
4.2.13	Instrument Information.....	29
4.3	Description of Operation.....	30
4.3.1	Method of Measurement.....	30
4.3.1.1	Voltage Fundamental Frequency Measurement Method.....	30
4.3.1.2	Voltage and Current Measurement Method.....	30
4.3.1.3	Harmonics and THD Evaluation Method.....	31
4.3.1.4	Power, Power Factor and Unbalance Evaluation Method.....	32
4.3.1.5	Temperature.....	33
4.3.1.6	“ The Fixscan” Mode („DC-500“).	33
4.3.1.6.1	Function.....	34
4.3.2	Measured Values Evaluation and Aggregation.....	35
4.3.2.1	Actual Values Evaluation and Aggregation.....	35
4.3.2.2	Average Values Evaluation.....	36
4.3.2.2.1	Maximum and Minimum Average Values.....	36
4.3.2.3	Recorded Values Aggregation.....	37
4.3.3	Embedded Electricity Meter.....	38
4.3.3.1	Electric Energy Processing.....	38
4.3.3.1.1	Standard Energy Presentation.....	38
4.3.3.1.2	Customizable Energy Screen.....	39
4.3.3.1.3	Recorded Values of Energy Aggregation.....	40
4.3.3.2	Maximum Demand Processing.....	40
4.3.3.2.1	Fixed Window MD Processing, Last Demand and Estimated Demand.....	41
4.3.3.2.2	Maximum Demand Presentation.....	41
4.4	Embedded Auxiliary Voltage Backup (SMP 133 only).....	42
5.	RESIDUAL CURRENT MONITORING (RCM).....	43
5.1	Measuring Transformers for the RCM.....	43
5.1.1	Electrical Safety.....	43
5.1.2	Standard RCTs with AC-Current Output.....	43
5.1.2.1	Overcurrent Protection.....	43
5.1.3	Special RCTs with DC-Current Output.....	44
5.2	RCM Inputs Connection.....	44
5.3	RCM Setup & Presentation.....	45
5.4	Tips & Hints.....	46
6.	INPUTS & OUTPUTS.....	47
6.1	Connection of the I/Os.....	48
6.1.1	Digital Output (DO, RO) Connection.....	50
6.1.2	Digital Input (DI) Connection.....	51
6.1.3	Analog Inputs Connection.....	51
6.1.4	External Pt100 Temperature Sensor Connection.....	51
6.1.4.1	„DT“ Models.....	51
6.1.4.2	„AT“ Models.....	52
6.2	I/O Setup.....	52

- 6.2.1 I/O Actions..... 53
 - 6.2.1.1 Digital Output (Standard, DO/RO)..... 53
 - 6.2.1.2 Alarm Light (A)..... 54
 - 6.2.1.3 Pulse Output (PO)..... 54
 - 6.2.1.4 Pulse Switch (Switch)..... 55
 - 6.2.1.5 Frequency Counter (FC)..... 55
 - 6.2.1.5.1 Frequency Mode..... 55
 - 6.2.1.5.2 PWM Mode..... 56
 - 6.2.1.6 Pulse Counter (PC)..... 56
 - 6.2.1.7 Analog Input (AI)..... 56
 - 6.2.1.8 Analog Output (AO)..... 57
 - 6.2.1.9 Send Message (Message)..... 57
 - 6.2.1.10 Send Email..... 58
 - 6.2.1.11 Show Note (SN)..... 58
 - 6.2.1.12 Hour Meter (HM)..... 60
 - 6.2.1.13 Time Synchronization (PPM/PPS)..... 60
 - 6.2.1.14 Archive Control..... 61
 - 6.2.1.15 General Oscillogram (GO)..... 61
 - 6.2.1.16 Variable (Var)..... 62
 - 6.2.1.16.1 Variable Value Monitoring and Manual Change..... 63
 - 6.2.1.17 Send SNMP Trap (SNMP Trap)..... 63
- 6.2.2 I/O Conditions..... 65
 - 6.2.2.1 Digital Input Condition..... 65
 - 6.2.2.2 Measured Quantity Condition..... 65
 - 6.2.2.2.1 Condition Limit Checking and Editing on Instrument Display..... 66
 - 6.2.2.3 Device State Condition..... 67
 - 6.2.2.3.1 Device State Events..... 67
 - 6.2.2.3.1.1 Flags..... 67
 - 6.2.2.3.1.2 Voltage and Power Quality Events..... 68
 - 6.2.2.3.1.3 Protection..... 69
 - 6.2.2.4 RCM Condition..... 69
 - 6.2.2.5 Time Condition..... 70
 - 6.2.2.6 Variable Condition..... 70
- 6.3 I/O Actual Data Presentation..... 70**
 - 6.3.1 Digital and Analog I/O..... 70
 - 6.3.2 Pulse Counters..... 71
- 6.4 I/O Block Processing..... 71**
 - 6.4.1 Digital Inputs..... 72
 - 6.4.1.1 Digital Input Filter..... 72
 - 6.4.1.2 Digital Input as Frequency Counter..... 72
 - 6.4.1.2.1 "Frequency" Mode..... 72
 - 6.4.1.2.2 "PWM" Mode..... 72
 - 6.4.1.3 Digital Input as Pulse Counter..... 72
 - 6.4.2 Digital Outputs..... 73
 - 6.4.2.1 Pulse Outputs..... 73

7. LOCAL BUS.....74

- 7.1 Connection..... 74
- 7.2 LED Indicators of Local Bus..... 76
- 7.3 Commissioning..... 77
 - 7.3.1 Local Bus Parameters Overview..... 81
 - 7.3.1.1 "Averaging" Block..... 81
 - 7.3.1.2 "Slaves Modbus Address Block" Block..... 81
 - 7.3.1.3 Configured Slaves Block..... 81

7.3.1.4	Detected but not Configured Slaves Block.....	84
7.3.2	Autodetect Option.....	84
7.4	Measured Data Presentation.....	86
7.4.1	ENVIS-DAQ Application.....	86
7.4.2	Instrument Display.....	87
7.4.2.1	Local Bus Actual & Average Data.....	87
7.4.2.2	Local Bus Energy Data.....	87
8.	COMPUTER CONTROLLED OPERATION.....	89
8.1	Communication Links.....	89
8.1.1	Local Communication Link.....	89
8.1.2	Remote Communication Links.....	89
8.1.2.1	RS-485 Interface (COM).....	89
8.1.2.1.1	Communication Cable.....	90
8.1.2.1.2	Terminating Resistors.....	90
8.1.2.2	Ethernet (IEEE802.3) Interface.....	90
8.2	Communication Protocols.....	90
8.2.1	KMB Communications Protocol.....	90
8.2.2	Modbus-RTU Communications Protocol.....	91
8.2.3	M-Bus Communications Protocol.....	91
8.3	Embedded Webserver.....	91
9.	FIRMWARE EXTENSION MODULES.....	92
9.1	Power Quality Module.....	92
9.2	Ripple Control Signal Module.....	92
9.3	General Oscillogram Module.....	93
9.4	Modbus Master Module.....	93
9.5	Ethernet-to-Serial Module.....	94
9.6	UDP Push Module.....	94
10.	EXAMPLES OF CONNECTIONS.....	95
11.	MANUFACTURED MODELS AND MARKING.....	104
12.	TECHNICAL SPECIFICATIONS.....	105
13.	MAINTENANCE, SERVICE.....	116

1. General

Measurement & Evaluation

- three measurement voltage inputs, star / delta / Aron connection
- three/four measurement current inputs for CTs nominal secondary output of 5/1 A or 0.1 A
- 10/12 periods evaluation cycle (200 ms at 50/60 Hz)
- continuous (gap-less) measurement of voltage and current
- evaluation of harmonic components up to 50th
- fixed window / floating window average values of all evaluated quantities with minimum & maximum values registration
- built-in electricity meter :
 - four-quadrant counters for both active and reactive energies at three tariffs
 - single phase and three phase energies
 - maximum of average active power value registration (maximum demand)
- built-in thermometer
- residual current inputs (certain models only)

Communication

- USB 2.0 communication port for fast data acquisition, configuration and firmware upgrades
- optional remote communication interface (RS 485 / Ethernet / M-Bus)
- proprietary protocol with free data acquisition software ENVIS
- MODBUS RTU /TCP protocols for simple integration with third party SCADA software
- embedded webserver (for instruments with Ethernet interface)

Datalogging Capabilities

- battery backed real time circuit (RTC)
- record interval from 0.2 second up to 1 hour
- high memory capacity for programmable recording of aggregated measurement values
- automated electricity meter readings at preselected time intervals



Inputs & Outputs (Depending on Instrument Model)

- digital outputs (relays or solid state)
- digital inputs
- 0 ÷ 20 mA_{DC} analog inputs
- Pt100 temperature sensor input

Design

- 96x96 mm plastic box for panel mounting
- TFT-LCD colour graphic display, 5 keys

1.1 Differences between SMY133, SMY134 and SMP133

	SMY133	SMY134	SMP133
number of current inputs	3	4	3
current crest factor at I _{NOM}	standard – 2.0	standard – 2.0	high – 17 (for recording of transient events)
measurement sampling frequency at 50 / 60 Hz	stand. model : 6.4 / 5.76 kHz model „G2“ : 25.6 / 23.04 kHz	25.6 / 23.04 kHz	25.6 / 23.04 kHz
measurement category of voltage inputs (model “230”)	300V CATIII	300V CATIII	300V CATIV
voltage & current measurement uncertainty class according IEC 61557-12	0.5	0.2	0.2
embedded auxiliary voltage backup	no	no	yes
protection class according IEC 61140	II - 	II - 	I - 

Other features are common.

2. Installation

2.1 Meaning of the symbols used on instrument



Warning – read operating manual !



AC – alternating voltage



DC – direct voltage



CE marking guarantees compliance with the European directives and regulations



The instrument must not be disposed of in the normal unsorted municipal waste stream



Basic insulation instrument (protection class I)



Double or reinforced insulation instrument (protection class II)

2.2 Physical

The instrument is built in a plastic box to be installed in a distribution board panel. As a rule, the panel is a part of a switchboard door - then the installation must be such that the switchboard door can be closed under all conditions of use. In any case, it must be ensured that only the front panel of the instrument is accessible to laypersons. Therefore, if the switchgear is located in an area accessible to laypersons, the switchgear door or panel must only be opened by means of a tool, or the door must be locked.

Fig. 2.1a : Panel Mounting

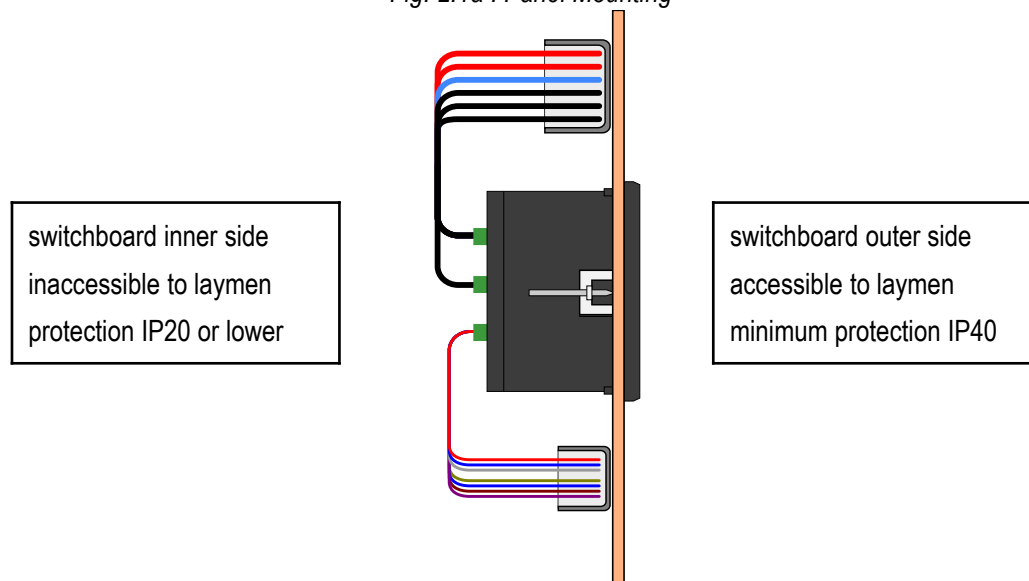

The instrument's position must be fixed with locks.

Natural air circulation should be provided inside the distribution board cabinet and in the instrument's neighbourhood no other instrumentation should be installed.

Fig. 2.1b : Space around the Instrument

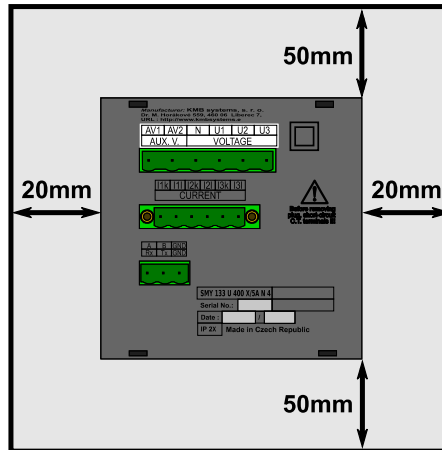

Especially underneath the instrument, no other instrumentation that is source of heat should be installed or the temperature value measured may be false.

2.3 Instrument Connection

2.3.1 Safety Grounding (SMP133 only)

As the SMP133 is safety class I type instrument, it must be grounded.

The instrument is equipped with the faston-type terminal 6.3 x 0.8 mm, marked \oplus (sometimes referenced as PE-terminal). Corresponding crimp-type receptacle is delivered with the instrument as standard accessory.

Fig. 2.2 : SMP 133 Grounding

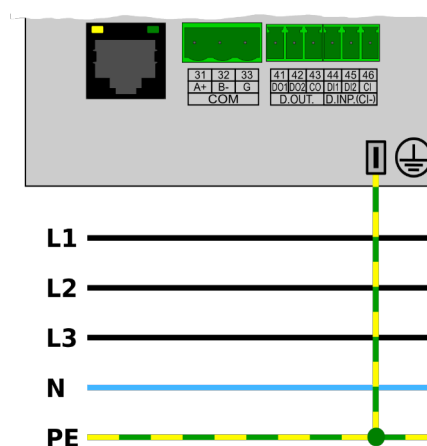

The terminal must be connected with the PE (or PEN) protection ground conductor (bare or with green/yellow coloured insulation).

Recommended wire type : H07V-U (CY)
 Recommended minimum conductor cross-section : 2.5 mm²
 Maximum conductor cross-section : 4 mm²



For safety reasons, the instrument must be grounded before connection of other signals!

2.3.2 Power Supply

The supply voltage (in range according technical specifications) connects to terminals **AV1** (No. 9) and **AV2** (10) via a disconnecting device (switch – see wiring diagram). It must be located at the instrument's proximity and easily accessible by the operator. The disconnecting device must be marked as such. A two-pole circuit breaker with the C-type tripping characteristics rated at 1A makes a suitable disconnecting device. Its function and working positions, however, must be clearly marked.

In case of DC supply voltage the polarity of connection is generally free, but for maximum electromagnetic compatibility the grounded pole should be connected to the terminal **AV2**.

Recommended wire type :	H07V-U (CY)
Recommended minimum conductor cross-section :	1.5 mm ²
Maximum conductor cross-section :	2.5 mm ²

2.3.3 Measured Voltages

The phase voltages measured are connected to terminals **U1** (12), **U2** (13), **U3** (14), the common terminal to connect to the neutral wire is identified as **N** (11; it stays free at delta- (3-D) and Aron- (A) connections). It is suitable to protect the voltage lines measured for example with 1A fuses. Measured voltages can also be connected via instrument voltage transformers.

Recommended wire type :	H07V-U (CY)
Recommended minimum conductor cross-section :	1.5 mm ²
Maximum conductor cross-section :	2.5 mm ²

2.3.4 Measured Currents

The instruments are designed for indirect current measurement via external CTs only. Proper current signal polarity (S1 & S2 terminals) must be observed. You can check the polarity by the sign of phase active powers on the instrument display (in case of energy transfer direction is known, of course).

It is necessary to set the CT-ratio – see example below.

The I2 terminals stay free in case of the Aron (A) connection.

2.3.4.1 Current Type Current Inputs Instruments (Models „X/5A“, „X/100mA“)

The current signals from 5A or 1A (or 0.1A for the „X/100mA“ models) instrument current transformers must be connected to the terminal pairs **I11**, **I12**, **I21**, **I22**, **I31**, **I32** (No. 1 ÷ 6). At the “134” model, you can connect the 4th current signal too to the terminals **I41**, **I42** (No. 7 ÷ 8).

Recommended wire type:	H05V-U (CY)
Recommended minimum conductor cross-section :	
• “X/5A” instruments :	2.5 mm ²
• “X/100mA” instruments :	0.75 mm ²
Maximum conductor cross-section :	2.5 mm ²

2.3.4.2 Voltage Type Current Inputs Instruments („X/333mV“ and „FLEX“ Models)

The instruments are equipped with separate connectors for particular measuring current input. Models „X/333mV“ and „FLEX“ differ from each other in the connector type used only :

- three-terminal flat connectors at „X/333mV“-models; each terminal has its unique number
- four-terminal rectangle connectors at „FLEX“-models; the connectors marked I1, I2, I3, I4 and all of them have the same terminal numbering

Function of the terminals is described in following tables :

“X/333mV“ Models Current Inputs Connection

terminal No.	signal
62, 65, 68, 71	S11, S12, S13, S14 ... signals corresponding to I1, I2, I3 and I4 currents (in phases L1, L2, L3, L4/N), CT terminal “S1”
63, 66, 69, 72	SG ... common pole of the I1 ÷I4 signals (CT terminals “S2”) and negative pole of the 5V built-in auxiliary power supply for current sensors (the terminals are interconnected)
61, 64, 67, 72	SP... positive pole of the 5V built-in auxiliary power supply for current sensors (the terminals are interconnected)

“FLEX“ Models Current Inputs Connection

terminal No.	signal
3	S1 ... signals corresponding to I1, I2, I3 and I4 currents (in phases L1, L2, L3, L4/N), CT terminal “S1”
4	S2 ... common pole of the I1 to I4 signals (CT terminal “S2”); the terminals are interconnected with each other and with pins No. 2 (= negative pole of the 5V built-in auxiliary power supply)
2	0V ... negative pole of the 5V built-in auxiliary power supply for current sensors; the terminals interconnected with each other and with pins No. 4 (common pole of current signals); dedicated for shield connection (if any)
1	+5V/P... positive pole of the 5V built-in auxiliary power supply for current sensors (the terminals are interconnected)

The instruments are designed for cooperation with current transformers with output nominal voltage of 333 millivolts. They can be also used with flexible current sensors (Rogowski coils) with embedded integrator of appropriate voltage output signal.

The CTs must be connected with two-wire twisted cable. Again, proper current signal polarity (CT secondary terminals S1, S2) must be observed.

Recommended wire type : twisted pair, for example KU03G24 (Nexans)

Recommended minimum conductor cross-section: 0.2 mm²

Maximum conductor cross-section: 1.5 mm²



Maximum length of the cable is 3 meters !

The flexible current sensors with embedded integrator usually require a power supply. For such purpose the instruments are equipped with auxiliary power supply 5V. Maximum load of each sensor connected is 20 mA.



At the „FLEX“ models, use terminal No. 2 for connection of shield if current sensors used are equipped with it.



*Connection of standard CTs with 5A or 1A nominal output current to the „X/333mV“ and „FLEX“ instruments is **forbidden** !!! Otherwise the instrument can be damaged !!!*

2.3.5 Other Inputs/Outputs

Connection of residual current inputs, other inputs, outputs and communication links are described in appropriate chapters further below.

3. Commissioning

3.1 Setup

When switching on the power supply, the instrument will display manufacturer's logo for short time and after that, one of actual data screen - for example the line-to-neutral voltages one - is displayed :



At this moment it is necessary to set *instrument parameters* that are essential for proper instrument measurement (so called *Installation group*) :

- mode of connection (direct measuring or via metering voltage transformers)
- type of connection (star, delta, Aron)
- ratio of CTs, VTs and their multipliers (if used)
- nominal voltage U_{NOM} and nominal frequency f_{NOM}
- I_{NOM} , P_{NOM} (not mandatory, but recommended)

3.1.1 Measured Electrical Quantities Installation Setup



For the proper data evaluation it is necessary to set all of the *Installation Setting* group parameters.

- **Connection Mode** determines if voltage signals are connected directly or if voltage transformers are used.
- **Connection Type** needs to be set according network configuration – wye (or star, **Y**) or delta (**D**, if neutral voltage potential not connected). Usually, all of three phases are connected so choose **3-Y** or **3-D**. For Aron connection set **3-A**. For single-phase connection, set **1-Y**.

- **CT** (CT_N , CT_{RCM}) - ratios must be specified, in case of “**via VT**” connection mode **VT**-ratio too.

The **CT** is valid for currents I_1 , I_2 and I_3 . If the fourth current input or residual current inputs are used, appropriate ratios CT_N / CT_{RCM} must be set too.



CT ratios can be set in form either .../ 5A or .../ 1A or .../ 333mV.

The **VT**-ratio must be set in form *Nominal primary voltage / Nominal secondary voltage* . For higher primary voltage values *the U-multiplier* must be used too.

- **I- and U-Multipliers** - You can modify any CT- / VT-ratio with this parameters. For example, to get better precision when using overweighted CTs, you can apply more windings of measured wire through the transformer. Then you must set the multiplier. For example, for 2 windings applied, set the multiplier to $1/2 = 0.5$.

For standard connection with 1 winding, the multiplier must be set to 1.

The CT_N and CT_{RCM} ratios have their extra I_N - and I_{RCM} -Multipliers.

Now you can browse through displayed actual values with the  and  and check if they correspond with reality.



For proper CT connection checking, you can use phasor diagram screen.

After measured quantities checked, other parameters (of RTC, averaging, remote communication etc.) can be set .

4. Detailed Description

4.1 Basic Functions

The instruments evaluate all of usual electric quantities like line-to-line and phase voltages, currents, active, reactive and apparent powers, power factors, voltage and current THDs and harmonic components, active and reactive energy, average power maximums, frequency etc. Furthermore, temperature is measured with built-in sensor. Optionally, the second temperature can be measured with an external Pt100 sensor at appropriate instrument models.

The instruments are fitted with inputs for connection of three voltage signals, three or four current signals (for connection of external CTs with either 5/1 A_{AC} or 0.1 A_{AC} or 333 mV_{AC} nominal secondary signal) and separate AC/DC power supply input. They can be used in both low and high voltage power grids.

The instruments feature three-rate tariff electricity meter with four-quadrant counters for both active and reactive energies and maximum average active power (maximum demand) registration. Advanced models store all results for actual and last month too and a separate archive dedicated for automated meter readings can record actual status in preselected intervals.

Certain models can be used for residual current monitoring too.

The instruments are equipped with battery backedup real-time circuit (RTC) and high capacity „Flash“ type memory for measured data and events recording.

The USB 2.0 communication link can be used for the instrument adjusting and recorded data transfer. For remote access, optional RS-485 or Ethernet or M-Bus communication interface is available. The instruments with Ethernet interface have embedded webserver.

Basic specifications of the instrument can be set up by using the inbuilt keyboard and the display. With the ENVIS program supplied as standard you can, via any of communication link, adjust the instrument and transfer recorded data. In addition to the instrument adjustment, ENVIS program allows you to display, view and archive the measured courses in the graphic form, as well as a number of other features.

4.2 Manipulation and Setting





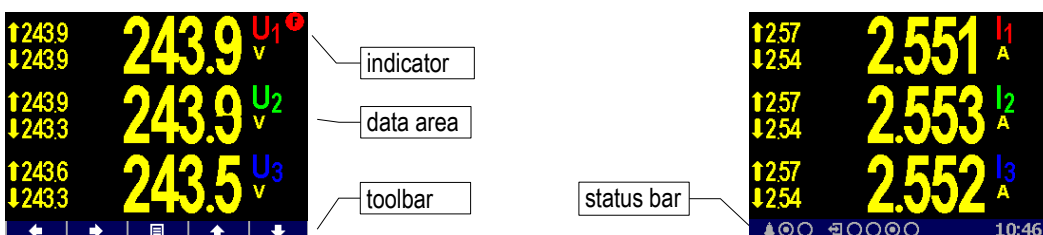

4.2.1 Data Area – Status Bar - Toolbar

The most usual data screen of an instrument consists of two parts : a *data area* and a *status bar / toolbar area*.

Fig. 4.1: Data Area, Data Area, Status Bar, Toolbar





After instrument's startup the status bar appears below data area as default. The status bar contains following information :

-    ... A1 and A2 alarm lights. After the bell icon, two targets represent actual state of the lights; the first one – A1 – is switched on on the example, the A2 is just switched off. This information appears only when either A1 or A2 function is set in the I/O management setup (see below).
-  ... digital I/O state. The instrument on example is equipped with four bidirectional inputs(DI)/outputs(DO) and either the DI3 input or DO3 output is just active.
Instruments equipped with unidirectional I/Os uses icon  for inputs and icon  for outputs.
- **10:46** ... local time (hours : minutes)

As soon as any button is pressed, a toolbar replaces the status bar. The toolbar determines function of individual buttons and changes dynamically by a context. If no manipulation with buttons for a longer period the toolbar is replaced with *the status bar*.





In special cases a flashing indicator can appear at upper right corner of the data area. It indicates following cases :

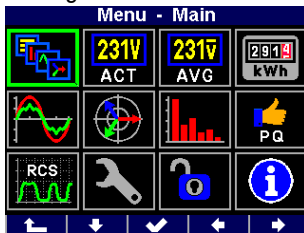

-  ... Frequency measurement not yet finished or out of range. In such cases measured signals are scanned according preset nominal frequency f_{NOM} and measured values can be incorrect. Check f_{NOM} parameter setting.
-  ... At least one of voltage or current input overloaded
-  ... At least one unconfirmed note is displayed in the *Note* user screen

4.2.2 Main Menu

Fig. 4.2: Main Menu



By pressing the , a *Main menu* window appears. With the  and  you can browse through the menu and select a desired action with the  or return back using the  (escape) button.

All other buttons but the  are context dependent and variable, but the  is accessible from nearly every window which helps to quick orientation.

Next chapters describe individual main menu options.



4.2.3 Main Data Group

This data group of screens is configurable by user. You can choose data screens you are most interested in and place them in this group for easy access. Use the ENVIS-DAQ program for the setup.

Assortment of available user screens follows :

Tab. 4.1: Available User Screens

screen	description
	<p>„3 Rows“</p> <ul style="list-style-type: none"> - up to three arbitrary quantities - single-phase or three-phase - actual, average, percentage values
	<p>„Summary Table“</p> <ul style="list-style-type: none"> - fixed assortment of basic quantities, no units - only k / M / G multipliers - in the last row voltage unbalance u2 [%] and frequency f [Hz]
	<p>„Waves“</p> <ul style="list-style-type: none"> - waveshapes of voltages and currents - including maximum of their peak values marked as Up/Ip.
	<p>„Phasor Diagram“</p> <ul style="list-style-type: none"> - actual voltage and current fundamental harmonic phasors - phase order (1-2-3 or 1-3-2)
	<p>„Harmonics“</p> <ul style="list-style-type: none"> - actual harmonic components of voltages and currents in histogram format - odd components from the 3rd to 25th only - THD values of individual phases
	<p>„Multiple“</p> <ul style="list-style-type: none"> - four compressed subscreens, each configurable individually - gauge type available (see details below)
	<p>„Digital Inputs“, „Analog Inputs“, „Pulse Counters“, „Hour Meter“</p> <ul style="list-style-type: none"> - actual data of digital/analog inputs & outputs - for details see <i>Inputs & Outputs</i> chapter
	<p>„Electricity Meter“</p> <ul style="list-style-type: none"> - up to three arbitrary energy quantities - see <i>Customizable Energy Screen</i> chapter further below for details

screen	description
	<p>„Modbus Master“</p> <ul style="list-style-type: none"> - actual values of quantities of slave units monitored by Modbus master module - see <i>Modbus Master Firmware Module</i> application note for details
	<p>„IO Variables“</p> <ul style="list-style-type: none"> - actual values of IO-variables - see <i>Variable Value Monitoring and Manual Change</i> in the <i>Inputs & Outputs</i> chapter for details
	<p>„IO Limits“</p> <ul style="list-style-type: none"> - values of meas. quantity condition limits - see <i>Condition Limit Checking and Editing on Instrument Display</i> in the <i>Inputs & Outputs</i> chapter for details
	<p>„Notes“</p> <ul style="list-style-type: none"> - see <i>Show Note</i> action description in the <i>Inputs & Outputs</i> chapter for details
	<p>„Local Bus“</p> <ul style="list-style-type: none"> - any of Local bus data screen can be added - see <i>Instrument Display</i> description in the <i>Local Bus</i> chapter for details
	<p>„Clear“</p> <ul style="list-style-type: none"> - allows clearing of average values, maximum demand values and electricity meter from this single screen - see „Clear“ <i>Screen</i> chapter for details

4.2.3.1 Gauge Type Subscreen in the „Multiple“ Screen

The screen consists of four compressed subscreens. Each of them can be configured individually.

Fig. 4.3: Screen „Multiple“

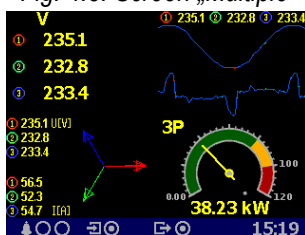

Type of the subscreens can be chosen from following :

- table
- waves
- phasors
- harmonics
- electricity meter
- gauge

Setup of all of types but the *gauge* is intuitive and needs no closer explanation.

The gauge type has four basic formats according to the control quantity chosen. They differ each from other in arrangement of colour bars of the scale – see below.

Each of gauges is marked with its quantity name in upper left corner of its subscreen. Actual value is displayed in numeric format too below the gauge.

Furthermore, marks of maximum (red) of average value registered since the last clearing and corresponding minimum (blue) value are displayed in most of gauge formats. For details see chapter *Average Values Evaluation* further below.



If no AVG-max & AVG-min marks displayed, maybe they are not yet available. This occurs always just after appropriate AVG-quantity group is cleared (see chapter Average Values Evaluation further below).

Tab. 4.2: Gauge Type Subscreen Formats

gauge format	range control parameter
<p style="text-align: center;">Voltage, Current</p>	<p>U_{NOM} / I_{NOM}</p>
<p style="text-align: center;">Power</p>	<p>P_{NOM} for three-phase powers $P_{NOM} / 3$ for single-phase powers</p>
<p style="text-align: center;">Frequency</p>	<p>f_{NOM}</p>

gauge format	range control parameter
<p style="text-align: center;">cosφ</p> 	<p>fixed arrangement no AVG-max/AVG-min marks (not evaluated for cosφ)</p>

4.2.3.2 „Clear“ Screen

This screen allows clearing of various registered values from one point. Moreover, timestamps of the last clearing of quantities' groups can be checked here.

From the screen you can clear these groups :

- registered maxima and minima of average values of U/I-group of quantities (see chapter *Average Values Evaluation* further below)
- registered maxima and minima of average values of P/Q/S-group of quantities
- registered maxima and minima of average values of residual currents (RCM)
- registered maximum demands (MD, see chapter *Maximum Demand Processing*)
- energy counters of electricity meter (see chapter *Embedded Electricity Meter*)

In the ENVIS-DAQ application, add the *Clear* screen and select it. In the right bottom corner you can set the screen properties :

Fig. 4.4: User Screens Setting - „Clear“

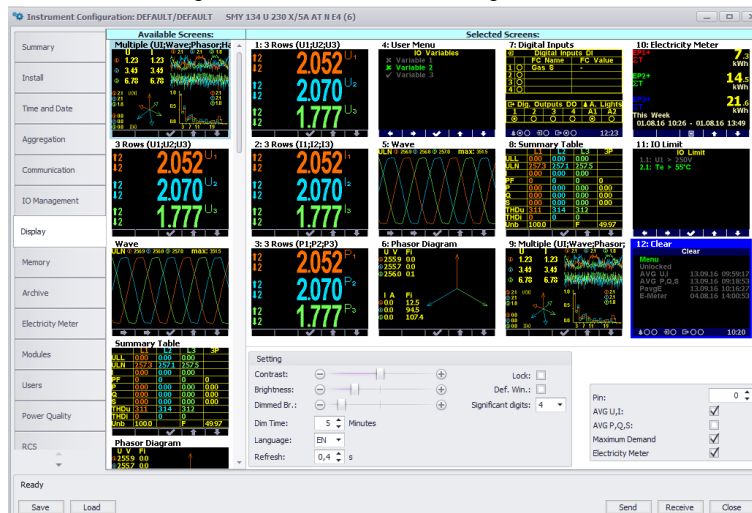

Check the quantity groups that you want to allow clearing from the screen – at the example above there are *AVG U/I*, *Maximum Demand* and *Electricity Meter* groups. Now send the setting into the instrument.



Now scroll through the instrument screens in the main data group and find the newly added screen. It should look like the example below.

Fig. 4.5: Screen „Clear“



The *Unlocked* informs that clearing of the quantities is not locked now.





Then list of quantity groups follows. At right of each group you can check timestamp of the last clearing.

With the  and  you can list the quantity group to be cleared. Then push the . After confirmation of the request, the corresponding group is cleared and its timestamp is updated.

The clearing can be locked by a special PIN. The lock operates as follows :

- if an instrument itself is unlocked (see the *Instrument Lock* chapter), the clearing is unlocked too (regardless to the *Clear PIN* setup)
- if the instrument is locked and the *Clear PIN* is set to zero, the clearing is unlocked
- if the instrument is locked and the *Clear PIN* is set to any value different from zero the clearing is locked

To lock the clearing, in the ENVIS-DAQ application set the *Clear PIN* to 1234, for example. Send the setup into the instrument. Then, if the instrument itself is unlocked, lock it – either with the ENVIS-DAQ (check appropriate checkbox in the display setup and send into the instrument) or via the instrument panel.

Now note that the item *Unlocked* has changed to **Locked**. In such case, if you need to clear any of groups you must to unlock the clearing first : list the *Locked* item and push the . At the right, a window with four digits appears. In the window set value to 1234 : with the  you can navigate between individual digits and set their values with the  and . Finally, push the .

If correct PIN set, the item changes to *Unlocked*. Now the clearing is possible.



The unlocking of clearing is temporary only ! As soon as you leave the screen, the clearing gets locked automatically !



To unlock the clearing permanently, in the ENVIS-DAQ application set PIN of the „Clear“ screen to zero and set the setting into the instrument. Optionally, unlock the instrument itself.

4.2.3.3 Default Window

By default, the instrument displays the last selected window (screen) of measured data until an operator switches to another. The instrument remembers the window even in the event of a power failure and displays it after the power is restored.

In the ENVIS-DAQ program, it is possible to force the instrument to automatically switch to the so-called *default window* if no one manipulates the buttons for a certain period of time. *The Default Window* is always the first user screen set in *the main data group* (see description in previous chapters). In the ENVIS-DAQ program, in *the Display* settings tab, place the desired screen first in the list, check *the Default Window* option (see the figure in the previous chapter) and send the settings to the device.

Then the set screen is displayed automatically about 5 minutes after no one manipulates the buttons.



4.2.4 Actual & Average Data Groups



Actual / Average values of measured data in numeric form are displayed in the groups. For detailed description of the actual values presentation see chapter *Display Actual Values Evaluation and Aggregation* further below.

All the values are identified with a quantity name and a quantity unit.

At the end of the *Actual* data group there is :

- I/O actual data window. For detailed description see chapter *I/O Actual Data Presentation*.
- If a data from slave units are monitored with so called *Modbus Master* feature, another table with actual data measured by the slave units is displayed. For details see *Modbus Master Module* chapter further below.



4.2.5 Electricity meter

In this data group you can check active & reactive energies registered in all quadrants. Next, maximum values of average three-phase active power including time stamps – so called maximum demands. For details see the chapter *Embedded Electricity Meter*.



4.2.6 Oscillograms

At this group there are actual waveshapes of all measured voltages and currents. With the



you can toggle between voltage and current screen.

They are also displayed effective values of the voltages/currents and maximum of their peak values marked as U_p/I_p .

Fig. 4.6 : Voltage Waves

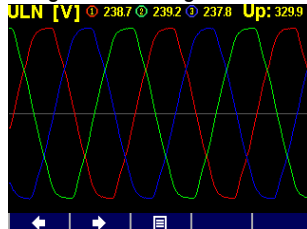

Fig. 4.7 : Current Waves



4.2.7 Phasor Diagram

Fig. 4.8 : Phasor Diagram

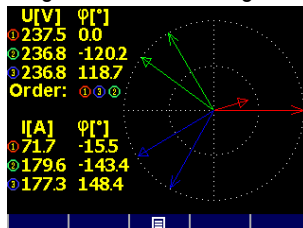

Diagram of actual voltage and current fundamental harmonic phasors.

Voltage phasor angles φ are absolute, current phasor angles are relative to appropriate voltage phasor ($\Delta\varphi$).

Phase order can be checked here too (indicated as **1-2-3** or **1-3-2**).



4.2.8 Harmonics & THDs

Actual harmonic components of all voltage and current signals in graphic (histogram) format. They are expressed in per cent of fundamental harmonic component.

Only odd components from the 3rd to 25th are displayed; for full spectrum of harmonics use ENVIS-DAQ program.

In the upper right corner, there are values of THD of individual phases.

Fig. 4.9 : Voltage Harmonics

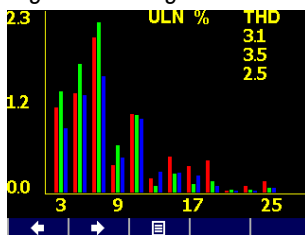
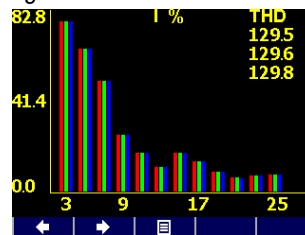

Fig. 4.10 : Current Harmonics



4.2.9 Power Quality & Voltage Events

This data group is available when appropriate firmware module is installed only.

On the first screen, there is “calendar” of power quality evaluation according the EN 50160 standard. Each day is marked with either or depending on that if power quality during the day was in compliance with the standard or not.

Next, there is the table of voltage events (VE). The events are sorted according magnitude and duration of each sag/swell/interruption and in the table you can check number of particular events registered since last clear. You can clear the VE-table in the PQ-setup screen.

Fig. 4.11 : Power Quality Calendar



Fig. 4.12 : Voltage Events Table

U<%	0.2	0.5	1	5	60s
90					
80					
70					
40	1				
5			1		
U>%	0.5	5	60s	Clear	
120				30.05.18	
110				15:23:02	

Detailed information of the PQ evaluation and the voltage events can be analyzed after downloaded into the ENVIS program.



4.2.10 Ripple Control Signal

This data group is available when appropriate firmware module is installed only.

At the screen you can check live graph of ripple control signal (mains signalling, U_{RC}) of chosen frequency. At the example there is starting part of a telegram of frequency 183 Hz on the L1 phase (U_{RC1}).

Fig. 4.13 : Ripple Control Signal Graph

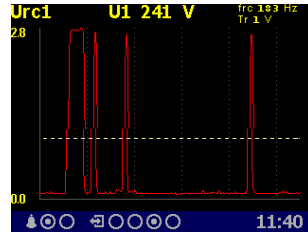

Fig. 4.14 : Ripple Control Signal Data Table

RCS			
Urc [V]	L1	L2	L3
act	3.6	3.6	3.6
avg	0.1	0.1	0.1
Last telegram L1			
avg1	3.7		
max1	3.9		
min1	3.5		
time	15.06.18 07:45:44		
frc=183.3Hz	Trig. Urc=1.0V		

With the and you can pass through all of phases measured. With the and you can toggle into the measured data table. There you can check :

- the upper part : actual and average (3 second floating window) values of the U_{RC1} , U_{RC2} , U_{RC3} ripple control signals
- the bottom part : average, maximum and minimum voltage of detected pulses (= when signal exceeds threshold U_{RCSTR}) registered during the last telegram.

With the and you can scroll through all measured phases.

The f_{RC} frequency and the U_{RCSTR} threshold voltage can be set in the RCS-setup screen.



4.2.11 Instrument Settings (Parameters)

In this group most of presetable parameters can be viewed and edited. Other parameters can be accessed via communication link using the ENVIS-DAQ program only.

If any of setting window is viewed, an instrument automatically reswitches to actual data display during an approx. 1 minute if no manipulation with buttons is carried out.

Following chapters explain the meaning of particular groups of parameters.



4.2.11.1 Display Setting

- **Contrast** ... Can be set in range 0 – 100%
- **Brightness** ... The brightness is activated in case of pressing of any button. It will be retained for *the dimming time* after the last press of a button.
- **Dimmed Brightness** ... For the instrument power consumption reduction and the display lifetime extension, it is activated after the set *dimming time* without any button manipulation has elapsed,.
- **Dimming Time** ... Explained above.
- **Default Window** ... Automatic switch to the so-called *default window* after no button manipulation occurs (see the chapter *Default Window* above).
- **Language** ... In addition to the basic English version, other language versions can also be set.
- **Display refresh cycle** ... Actual values refresh period. For details see chapter *Display Actual Values Evaluation and Aggregation*.
- **Display Resolution** ... Actual & average data groups format be set to 3 or 4 significant figures.



4.2.11.2 Installation Setting

All parameters of this group are explained in chapter *Measured Electrical Quantities Installation Setup*. above (*the Commissioning part*).



4.2.11.3 Remote Communication Setting

Communication parameters for various interface types differ from each other :

COM (RS-485) interface :

- **Communication Address**
- **Communication Rate** ...in Bauds (Bd)
- **Data Bits** ... including parity bits! Set to 8 for KMB-protocol; set to 9 when parity bit is used (Modbus-protocol, for example)
- **Parity** ...none/even/odd
- **Stop Bits** ... set to 1 (usually)

Ethernet interface :

- **DHCP** ... activation of dynamic IP-address allocation
- **IP Address** ...internet protocol address
- **Subnet Mask** ...subnet mask
- **Default Gateway** ...default gateway
- **KMB-port** ... communication port used for KMB protocol communication (2101 as default)
- **Web-port** ... communication port used for webserver communication (80)
- **Modbus-port** ... communication port used for Modbus protocol communication (502)

Nex information can be found in chapter *Computer Controlled Operation* below.



4.2.11.4 Clock Setting

- **Date & Time** ... Local date and time
- **Time Zone** ... The time zone should be set according location of an instrument during installation. Correct setting is essential for proper local time interpretation.
- **Daylight Saving** ... This option controls automatic winter/summer local time switching
- **Time Synchronization** ... As the built-in real time circuit has limited accuracy while free running, with this option it is possible to keep the RTC time in synchronism with an external precise time source. The RTC can be synchronized by :
 - **Pulse Per Second / Minute (PPS / PPM)** ... A digital input is used for time synchronization from an external source at this case. The instrument sets the RTC to the nearest second or minute as soon as a synchronization pulse is detected. Second-, Minute-, quarter-hour- or hour- synchronization pulses are accepted.
 - **NMEA Message** ...If an instrument is equipped with the RS-485 remote communication interface an external (usually GPS-based) time receiver can be connected to. The receiver must be set to transmit the "ZDA"- or "RMC "-message (NMEA 0183 protocol). The communication interface must be set appropriately (usually 4800 Bd, 8 bits, 1 stopbit).
 - **NTP Server** ...The option can be used if an instrument is equipped with the Ethernet communication link and a NTP-server is available in the network. Set IP-address of the server. Time synchronization period is adjustable (15 minutes as default).
 - **Network Frequency** ... For this option, the nominal frequency f_{NOM} parameter must be set properly. Otherwise the synchronization will not work.



Warning : When editing clock parameters, it must be taken into account that internal data archives are affected : when changing the date or time, **all archives are cleared** !



4.2.11.5 Average Values Processing Setting

In this parameter group average values processing for the *U/I*-, *P/Q/S*- and, optionally *RCM*-group of measured quantities can be set. Detailed explanation can be found in the chapter *Average Values Evaluation* further below.



4.2.11.6 Embedded Electricity Meter Setting

In this group parameters concerning electric energy registration and maximum active power demand processing (MD) can be set. For detailed parameter description see the chapter *Embedded Electricity Meter* further below.



4.2.11.7 Power Quality & Input/Output Setting

There are only overviews of parameters. To edit them, use the ENVIS-DAQ program.



You can only clear the voltage events table in the power quality setup group.



4.2.11.8 Ripple Control Signal Setting

- **Method** ... Method of the signal evaluation can be set either to *Filter* or in compliance with the *IEC61000-4-30* standard
- **f_{RC}** ... frequency of the ripple control signal in Hz
- **U_{RC} unit** ... ripple control voltage unit : either V or percent of **U_{NOM}**
- **U_{RC} threshold (U_{RC(CTR)})** ... minimum signal level to be recognized as „pulse“. Relevant for telegram detection, signal below the threshold is recognized as „gap“.



4.2.12 Instrument Lock

To be protected against unauthorized changes or access, an instrument can be locked.

You can lock the instrument in two different ways :

- directly from the instrument panel
- via a communication link with the ENVIS-DAQ program using so called *user management setup* (see below)

The actual lock state is symbolized in *the main* menu by its icon :



- **Unlocked** – anyone with physical access to the instrument panel can freely set-up and configure all parameters in the instrument, clear archives and other persistent data or reset counters.





- **Locked** – a password (PIN) is required before any configuration change is requested.





Exclusion : You can change the display setting group parameters even if the instrument is locked ! These are the only parameters that are free to change always.

4.2.12.1 Locking from the Instrument Panel

To lock the instrument, simply switch in the **Menu-Lock** window the lock from  to . Then escape from the window with the  and confirm saving of changed state.

4.2.12.2 Unlocking from the Instrument Panel

To unlock the instrument, switch in **Menu -> Lock** the lock state back from  to  by entering a PIN.

When the instrument was locked from the instrument panel, the value of this PIN is fixed and equal to the last four digits of the serial number of the instrument. This serial number can be found in device display under **Menu -> Info -> Serial number** .

When the instrument was locked by the user management, you need the PIN defined in the management (see below).

Then escape from the **Lock** window with the  and confirm saving of changed state.



*Note, that unlocking **the user management locked state** from the instrument panel is **temporary** and the instrument will switch to the locked state automatically approx. 15 minutes after last pressing of any button. To unlock such instrument permanently, use the user management.*

4.2.12.3 Locking/Unlocking by the User Management

Fig. 4.15 : User Management Locked Instrument



With the user management you can use more complex and sophisticated access control to the instrument not only from the instrument panel, but from all of communication interfaces.

You can check if the user management lock is used in the **Menu -> Lock** screen – at least one additional parameter *user* is displayed.

In such case, the PIN described in the previous chapter is inapplicable and the PIN defined in the user management is necessary for unlocking. Furthermore, more users with their private PINs can be defined.

So, when you want to change anything from the instrument panel, you

must :

1. choose the user (*Peter* in our example)
2. enter the PIN corresponding this user in the user management setup

For details see the application note No. 004 : *Users, passwords and PINs*.



In case the PIN is lost, ask manufacturer for alternate PIN via manufacturer's website at www.kmbystems.eu .



4.2.13 Instrument Information

- **Instrument Model & Serial Number** ... Instrument hardware model & serial No.
- **Instrument Hardware, Firmware & Bootloader Versions** ... Instrument hardware & firmware specification.
- **Object Number** ... Measured node specification (preset by ENVIS-DAQ program for data identification).
- **Vbatt** ... Backup battery voltage (if equipped)
- **Error Code** ... Indicates some instrument's hardware or setting problem. At normal state equals to 0. In case of detection of any error it contains a number created as the sum of binary weights of the errors. The following table provides overview of them and recommended action:

Tab 4.3 : Instrument Errors

Error No. (weight)	Error	Action
1	RAM memory error	set the instrument (optimally with the ENVIS program, if possible) to the <i>default setting</i> ; if the error appears again send the instrument to a service organization for repair
2	instrument setup error	set the instrument (optimally with the ENVIS program, if possible) to the <i>default setting</i> ; if the error appears again send the instrument to a service organization for repair
4	calibration error	the instrument must be recalibrated – send to a service organization
8	wireless communication module error (Wifi/Zigbee)	send to a service organization
16	RTC error	in <i>the time setup window</i> (or better with the ENVIS program, if possible), set actual date&time; if the error appears again, check built-in backup battery; otherwise send the instrument to a service organization for repair
128	archive data error	clear all of the archives with the ENVIS program; if the error appears again send the instrument to a service organization for repair
256	FLASH memory error	send to a service organization
512	display error	send to a service organization
1024	SD-card error	if indicated while a card inserted only, replace the card if indicated while the card ejected too, send to a service organization

4.3 Description of Operation

4.3.1 Method of Measurement

The measurement consists of three processes being performed continuously and simultaneously: frequency measuring, sampling of voltage and current signals and evaluation of the quantities from the sampled signals.

4.3.1.1 Voltage Fundamental Frequency Measurement Method

The voltage fundamental frequency is measured at the U1 voltage signal. It is measured continuously and evaluated every 10 seconds.

The fundamental frequency output is the ratio of the number of integral mains cycles counted during the 10 second time clock interval, divided by the cumulative duration of the integer cycles.

If value of frequency is out of measuring range, such state is indicated with flashing indicator  at upper right corner of the actual data window.

4.3.1.2 Voltage and Current Measurement Method

Both voltage and current signals are evaluated continuously as required by IEC 61000-4-30, ed. 2 standard. The unitary evaluation interval, a *measurement cycle*, is a ten / twelve (value behind slash is valid for $f_{NOM} = 60$ Hz) *mains cycles* long period (i.e. 200 ms at frequency equal to preset f_{NOM}), which is used as a base for all other calculations.

The sampling of all voltage and current signals is executed together with the frequency of 128 / 96 samples per mains cycle. The sampling rate is adjusted according to the frequency measured on any of the voltage inputs **U1**, **U2**, **U3**. If the measured frequency is in measurable range at least on one of these inputs, then this value is used for subsequent signal sampling. If the measured frequency is out of this range, the preset frequency value (f_{NOM}) is used and measured values may be incorrect.

When exceeding the measuring range of any voltage or current, the instrument indicates overload by indicator  at upper right corner of the actual data window.

From the sampled signals, following quantities over the measurement cycle are evaluated (examples for phase No. 1) :

DC-component of phase voltage (mean value) :

$$U_{DC1} = \frac{1}{n} \sum_{i=1}^n U_{1i}$$

AC-component of phase voltage (rms value) :

$$U_1 = \sqrt{\frac{1}{n} \sum_{i=1}^n (U_{1i} - U_{DC1})^2}$$

Line voltage (rms value of AC-component) :

$$U_{12} = \sqrt{\frac{1}{n} \sum_{i=1}^n ((U_{1i} - U_{DC1}) - (U_{2i} - U_{DC2}))^2}$$

Current (rms value of AC-component) :

$$I_1 = \sqrt{\frac{1}{n} \sum_{i=1}^n I_{1i}^2}$$



DC-component of the line voltage is not evaluated.

The instrument current inputs have an AC-coupling and do not allow the DC-component measurement.

Meaning of the quantities :
 i sample index
 n number of samples per measurement cycle (1280 / 1152)
 U_{i1}, I_{i1} ... sampled values of voltage and current

Phase Current Sum :
$$\sum I = I_1 + I_2 + I_3$$

The data for the longer measurements are aggregated from these measurement cycles. Long time interval starts after the RTC tick occurrence at the beginning of the next measurement cycle time interval. This principle enables to configure other intervals up to 2 hours for datalogging purposes.

Measured phase voltages U₁ to U₃ correspond to the potential of terminals **VOLTAGE / U1** to **U3** towards the terminal **VOLTAGE / N**.



Measuring voltage inputs impedance is in range of units of MΩ. If no signal connected (for example when protection fuse is blown), due to parasite impedance of power supply input a parasite voltage of up to tens of volts can appear on the measuring voltage inputs. In such case the instrument can show non-zero voltages !

At the star (wye, 3Y) connection, three current signals - I₁, I₂, I₃ - are measured. Another current is calculated from samples of directly measured ones as negative vector sum of current vectors I₁, I₂, I₃ (Kirchhoff rule). The calculated current is referenced as I_{NC}.

If an instrument is equipped with four current inputs, the fourth current I₄ is measured too. Then another current, referenced as I_{PEC}, is calculated as negative vector sum of current vectors I₁, I₂, I₃, I₄.

At the Aron (3A) connection, the current I₂ is not measured, but it is calculated as negative vector sum of current vectors I₁ and I₃.

4.3.1.3 Harmonics and THD Evaluation Method

Entire spectrum of harmonic components and THD is evaluated discontinuously - periodically every second from 10 / 12 mains cycles long signal according to IEC 61000-4-7 ed.2 as harmonic sub-groups (H_{sg}).

Following quantities are evaluated :

Harmonic components of voltage and current up to 50th order : U_{ih1}, I_{ih1}
 (i order of harmonic component)

Absolute angle of voltage harmonic component phasor : φ_{Uih1}

Current harmonic component phasor angle relative to phasor U_{fh1} : φ_{Iih1}

Relative angle between correspondent voltage and current phasors : Δφ_{i1}

Total harmonic distortion of voltage :
$$THD_{U1} = \frac{1}{U_{1h1}} \sqrt{\sum_{i=2}^{40} U_{ih1}^2} * 100 \%$$

Total harmonic distortion of current :
$$THD_{I1} = \frac{1}{I_{1h1}} \sqrt{\sum_{i=2}^{40} I_{ih1}^2} * 100 \%$$

4.3.1.4 Power, Power Factor and Unbalance Evaluation Method

Power and power factor values are calculated continuously from the sampled signals according to formulas mentioned below. The formulas apply to basic type of connection – wye (star).

Active power :

$$P_1 = \sum_{k=1}^N U_{k,1} * I_{k,1} * \cos \Delta \varphi_{k,1}$$

Reactive power :

$$Q_1 = \sum_{k=1}^N U_{k,1} * I_{k,1} * \sin \Delta \varphi_{k,1}$$

where : k ... harmonic order index, odd components only

N ... order of the highest harmonic component (depends on the instrument type and the f_{NOM} setting, see the technical specifications below)

$U_{k,1}, I_{k,1}$... the k^{th} harmonic components of voltage and current (of phase 1)

$\Delta \varphi_{k,1}$... angle between the k^{th} harmonic components $U_{k,1}, I_{k,1}$ (of phase 1)

(these harmonic components of U and I are evaluated from each measurement cycle)

Apparent power :

$$S_1 = U_1 * I_1$$

Distortion power :

$$D_1 = \sqrt{S_1^2 - P_1^2 - Q_1^2}$$

Power factor :

$$PF_1 = \frac{|P_1|}{S_1}$$

Three-phase active power: :

$$\sum P = P_1 + P_2 + P_3$$

Three-phase reactive power :

$$\sum Q = Q_1 + Q_2 + Q_3$$

Three-phase apparent power :

$$\sum S = S_1 + S_2 + S_3$$

Three-phase distortion power :

$$3D = \sqrt{3S^2 - 3P^2 - 3Q^2}$$

Three-phase power factor :

$$\sum PF = \frac{|\sum P|}{\sum S}$$

Fundamental harmonic component quantities :

Fundamental harmonic power factor :

$$\cos \Delta \varphi_1 \quad (\text{or} \quad \tan \Delta \varphi_1, \Delta \varphi_1)$$

Fundamental harmonic active power :

$$P_{fh_1} = U_{fh_1} * I_{fh_1} * \cos \Delta \varphi_1$$

Fundamental harmonic reactive power : $Q_{fh_1} = U_{fh_1} * I_{fh_1} * \sin\Delta\varphi_1$

Fundamental harmonic three-phase active power : $\sum P_{fh} = P_{fh_1} + P_{fh_2} + P_{fh_3}$

Fundamental harmonic three-phase reactive power : $\sum Q_{fh} = Q_{fh_1} + Q_{fh_2} + Q_{fh_3}$

Fundamental harmonic three-phase power factor : $\sum \cos\Delta\varphi = \cos\left(\arctg\left(\frac{\sum Q_{fh}}{\sum P_{fh}}\right)\right)$

Powers and power factors of the fundamental harmonic component ($\cos \varphi$) are evaluated in 4 quadrants in compliance with the standard IEC 62053 – 23, apendix C :

Fig. 4.20 : Identification of consumption- supply and the character of reactive power according to phase difference

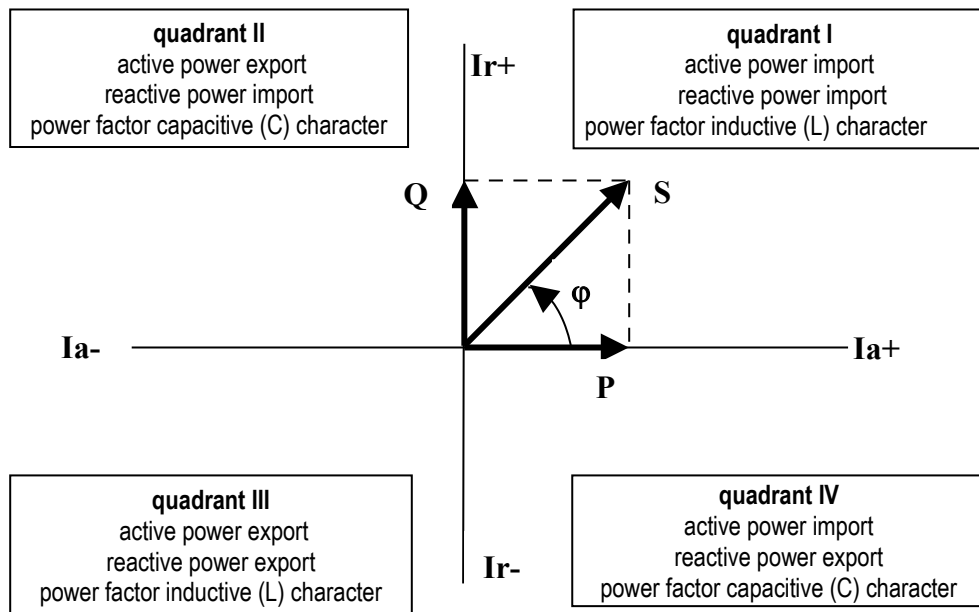

For outright specification of the quadrant, the power factor of the fundamental harmonic component – $\cos \varphi$ – is expressed according to the graph with two attributes :

- a *sign* (+ or -), which indicates polarity of active power
- a *character* (**L** or **C**), which indicates the power factor character (the polarity of reactive power relative to the active power)

Voltage and current unbalance evaluation is based on negative/positive sequences of voltage and current fundamental harmonic components :

Voltage unbalance : $unb_V = \frac{\text{voltage negative sequence}}{\text{voltage positive sequence}} * 100\%$

Current unbalance : $unb_I = \frac{\text{current negative sequence}}{\text{current positive sequence}} * 100\%$

Current negative sequence angle : φ_{nsl}

All of angle values are expressed in degrees in range [-180.0 ÷ +179.9].

4.3.1.5 Temperature

Both the internal temperature T_i and the external temperature T_e (at selected models only) are measured and updated each approx. 10 seconds.

4.3.1.6 “ The Fixscan” Mode („DC-500“)

The instrument is primarily designed to measure distribution networks with the nominal frequency of 50 or 60 Hz. Sampling, processing, and aggregation of a measured signal when setting the f_{NOM} parameter to one of these two values is described above and corresponds to the standards specified in technical parameters.

However, there are other applications, such as:

- networks with $f_{NOM} = 400$ Hz
- variable frequency networks, such as output of frequency inverters

The *Fixscan mode* is used to measure such networks.

4.3.1.6.1 Function

The *Fixscan mode* is activated by setting the f_{NOM} parameter to "DC-500". The device then works as follows:

- U and I signals sampled at the fixed sampling frequency of 6400 Hz
- fixed evaluation interval of measured quantities every 200ms
- DC component of voltage is also evaluated (DC component of current not measured)
- assortment of measured quantities is limited according to the table below; other variables, such as harmonic components, THDs, unbalances are not measured in this mode
- measurement uncertainties are defined by a separate table (see technical parameters)

The frequency of the measured signal can be in the range of 0 - 500 Hz.



Due to the fixed evaluation window (200ms), a systematic error of incomplete number of evaluated waves may occur, especially in low frequency signals !

Temperature and analogue inputs are measured in the same way as in standard mode. Similarly, energy is evaluated standardly by integration of appropriate power.

Tab. 4.4 : The Fixscan Mode Quantities Measured Overview

Mark	Quantity	Evaluation method
f	frequency of voltage	voltage signal digital filtration + zero crossing period measurement
U1	phase-to-neutral alternating voltage (effective value)	$U1 = \sqrt{\frac{1}{1280} \sum_{i=1}^{1280} U_{i1}^2}$
Udc1	direct phase-to-neutral voltage (direct component of the signal)	$U_{dc1} = \frac{1}{1280} \sum_{i=1}^{1280} U_{i1}$
U12	phase-to-phase alternating voltage (effective value)	$U12 = \sqrt{\frac{1}{1280} \sum_{i=1}^{1280} (U_{i1} - U_{i2})^2}$
I1	alternating current (effective value)	$I1 = \sqrt{\frac{1}{1280} \sum_{i=1}^{1280} I_{i1}^2}$
P1	active power	$P1 = \frac{1}{1280} \sum_{i=1}^{1280} U_{i1} * I_{i1}$
Q1	non-active power	$Q1 = \sqrt{S1^2 - P1^2}$
S1	apparent power	$S1 = U1 * I1$
PF1	power factor	$PF1 = \frac{ P1 }{S1}$

Note : marks and evaluation formulas shown for phase No. 1

4.3.2 Measured Values Evaluation and Aggregation

As described above, measured values are evaluated according to IEC 61000-4-30 ed.2, based on continuous (gap-less), 10 / 12 mains cycles long intervals (measurement cycle) processing.

Further aggregation of the actual values from this evaluation is used to obtain values for displaying and recording.

4.3.2.1 Actual Values Evaluation and Aggregation

Actual (instantaneous) values of measured quantities, that can be viewed on instrument's display, are evaluated as average of integral number of measurement cycle values per *display refresh cycle*.

The display refresh cycle is presetable in range 2 - 20 measurement cycles , corresponding approx. to 0.4 - 4 seconds display refresh cycle duration.

Maximum (marked as ↑) and minimum (↓) measurement cycle values registered during the display refresh cycle interval are displayed too.

Fig. 4.21 : Actual Data Display Refresh Cycle Setting

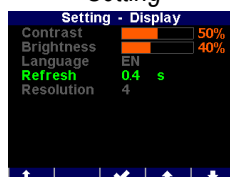
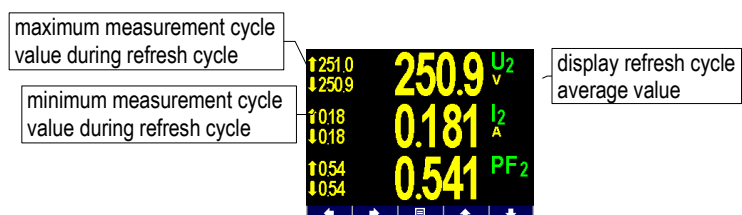

Fig. 4.22 : Actual Data



Exceptions :

- frequency – the value is refreshed each frequency measurement cycle (see above)
- harmonic components, THD and unbalance – the last measurement cycle values are displayed (no averaging)
- temperature – the value is refreshed each temperature measurement cycle (see above)

Actual values, read from an instrument via a communication link for monitoring purposes are evaluated from one – the last – measurement cycle only.



Neither maximum nor minimum of $\cos\phi$ values are evaluated due to special character of the quantity. Similarly, these extreme values are not evaluated at frequency, harmonics&THD and temperature values either due to a specific measurement method.

4.3.2.2 Average Values Evaluation

From measurement cycle values, average values of all basic quantities are calculated. Following parameters can be set to control the way of averaging :

- averaging method, which can be set to one of :
 - fixed window
 - floating window
- averaging period in range from 0.2 second to 1 hour

When **fixed window** averaging is set, values are calculated from fixed block intervals. The values are updated at the end of every interval. Beginnings of the intervals are synchronized to the nearest whole time (for example, when averaging period is set to 15 minutes, the average values are updated four times per hour in xx:00, xx:15, xx:30 and xx:45).

When **floating window** is set, the exponential moving average is evaluated.

Average values processing can be set independently for so called **U/I** -group, **P/Q/S** -group and optionally for the **RCM**-group of quantities.. Following table lists processed quantities of all of groups.

Tab. 4.5 : Average Values Groups

Average values group	Averaged quantities
“ U / I ”	U_{LL}, U_{LN}, I, f, T
“ P / Q / S ”	P, Q, S, PF, Pfh, Qfh, $\cos\phi$
“ RCM ”	$I\Delta$ (residual currents)



After the average parameters set, evaluation of average values starts from beginning. The average values are temporary not available until the first averaging window expires.



*Preset averaging parameters noted above are valid for so called standard average values. For the maximum power demand **MD** in the Electricity Meter group, separate parameter is used (see below).*

4.3.2.2.1 Maximum and Minimum Average Values

Maximum and minimum values of average values are registered into the instrument's memory, including the date & time of their occurrence.

The maximums&minimums are displayed on the left side of average values window - maximum value is identified with the \uparrow symbol and minimum value with the \downarrow symbol.

To view their time stamps, press the  .

Fig. 4.23 : Average Data Processing Setting



Fig. 4.24 : Average Data

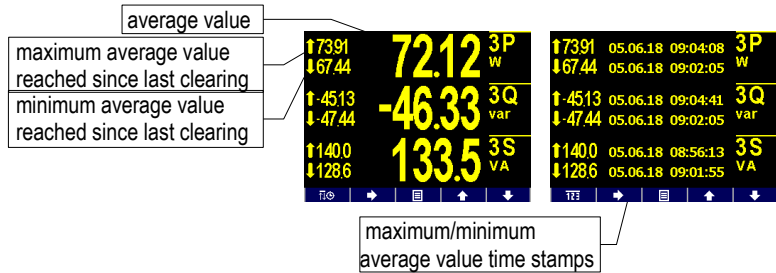

The maximum and minimum registered values can be cleared either manually or automatic clearing can be set.

To clear the values manually, navigate to appropriate average group setup screen and use **Clear** option. At this screen last clear date can be checked too.

To activate automatic clearing of maximums/minimums of average values, set the automatic clear period.



Only the appropriate group (U/I or P/Q/S or RCM) of average maxs/mins is affected by single clearing ! Each group must be cleared or set individually



After clearing of registered average maxima/minima, evaluation of appropriate average values starts from beginning. After that, both the average values and their registered maximums/minimums are temporary not available until new averaging window expires.



For manual clearing of registered average maxima/minima so called „Clear“ user screen can be used. See Main Data Group chapter for details.

4.3.2.3 Recorded Values Aggregation

All of measured and evaluated data can be optionally archived into the instrument's memory. The record period is presettable in a wide range and aggregated data are archived.

The shortest aggregation interval is 0.2 s while the longest configurable interval is 2 hours. If aggregation interval below 1 minute is selected then evaluation is aggregated according to cycle count at actual frequency. For intervals longer than one minute the aggregation is carried out according to a real time tick.

Where applicable not only the average value but minimum and maximum values over aggregation interval can be stored too.

4.3.3 Embedded Electricity Meter

For electric energy measurement, stand-alone unit – *electricity meter* - is implemented inside instruments. Energies are evaluated in compliance of the IEC 62053-24 standard : active energy from full harmonic spectrum and reactive energy from the fundamental harmonic component only.

Except of electric energy, maximum active power demands are registered in the unit.

4.3.3.1 Electric Energy Processing

Measured values of electrical energy are recorded separately in four quadrants : active energy (**EP**) consumed (+, import), active energy supplied (-, export), reactive energy (**EQ**) inductive (**L**) and reactive energy capacitive (**C**). Both single-phase and three-phase energies are processed.

In addition, three-phase energies are evaluated in three preset tariff zones (time of use). The actual tariff can be controlled either by an actual RTC time using preset tariff zone table with one hour resolution or by an external signal through a digital input.

Internal energy counters have sufficient capacity in order not to overflow during the whole instrument lifetime. On the instrument's display only 9 digits can be viewed – therefore, after energy value exceeds 999999999 kWh/kvarh, instrument's display format automatically switches to MWh/Mvarh, then to GWh/Gvarh.

The electricity meter data can be periodically archived with a preset registering interval into the instruments memory and can be analysed later after being downloaded into a PC.



4.3.3.1.1 Standard Energy Presentation

Electricity meter energy data are situated in a separated group of screens, which is accessible via the main menu.

As default , so called **2Q** branch is displayed (at the left on the map). The 1st screen shows actual three-phase energies registered since last clearing up to now for all tariff zones (**ΣT**) :

- **3EP+** ... imported active energy
- **3EP-** ... exported active energy
- **3EQL** ... imported reactive energy (inductive, **L**)
- **3EQC** ... exported reactive energy (capacitive, **C**)

Scrolling down, individual phase energies can be checked too.

Navigating to the right you get into the **4Q/T** branch. This presentation brings individual reactive energies registered during active power import and export, that can be useful especially for monitoring of renewable sources. For example :

- **3EQL+** ... registered, when three-phase active power **3P** is positive (+ = import)
- **3EQL-** ... registered, when three-phase active power **3P** is negative (- = export)

Scrolling down you can check these energies registered in individual tariff zones **T1**, **T2** and **T3**.

Finally, at the right branch **4Q/L** you can browse through energies of individual phases **L1**, **L2**, **L3** (for all three tariff zones).

Tariff zones can be set via a communication link using the program ENVIS-DAQ.

Energy counters can be cleared either manually or with a remote PC. Manual clearing can be invoked by the **Clear** option in the electricity meter setup screen. There you can check time & date of the previous clearing too.



For manual clearing of the energy counters, so called „Clear“ user screen can be used. See Main Data Group chapter for details.

Fig. 4.28 : Electricity Meter Screen Map

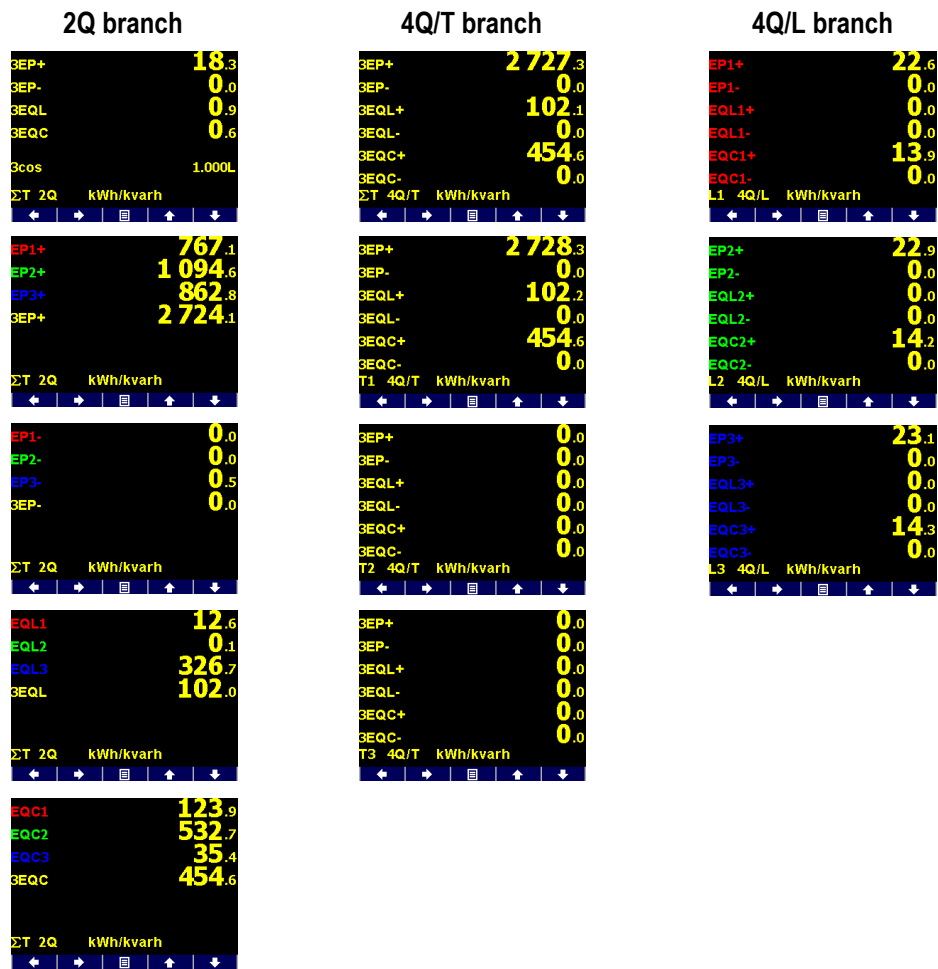

4.3.3.1.2 Customizable Energy Screen

With the ENVIS-DAQ program you can add special user configurable electricity meter screen into the main data group. In the screen you can choose not only energies you are interested in, but processing period too.

The processing period can be selected from :

- **Actual** ... energies registered since the last clearing
- **This Month/Week** ... energies registered during present month/week
- **Last Month/Week** ... energies registered during last month/week
- **Bookmark** ... energies registered since defined date & time (=bookmark)

For example, when you are interested in imported three-phase active energy registered since 11 o'clock of 5th June 2018, create such custom screen in the ENVIS-DAQ program, choose evaluation period to *bookmark* and set its date & time. Then desired screen appears in the main data group.

Fig. 4.29 : Electricity Meter Setting



Fig. 4.30 : Custom Electricity Meter Screen with Bookmark

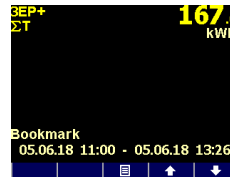

When you set the processing period, note that energies evaluated in this screen are calculated according values stored in the electricity meter archive. If such record is not stored in the archive, the evaluated energies can be false. To get correct values, the electricity meter archive recording must be set appropriately and the archive must be filled with sufficient depth of data. Attention must be paid whenever the electricity meter archive is cleared!

4.3.3.1.3 Recorded Values of Energy Aggregation

All of electricity meter readings can be optionally archived into the separate archive. Use the ENVIS-DAQ for the electricity meter archive setup.

You can set the *record period* that defines how often the electricity meter state is stored into the memory. Minimum record period is 1 minute. The electricity meter history can be later downloaded into a PC and analysed.

Actual tariff can be controlled either by actual local time using the *tariff zones table* or by a digital input. In case of *table* selection, a day long timetable for 3 different tariff selections with hourly resolution can be defined.

In case of the *digital input* selection, chosen digital input specifies actual tariff – open state means tariff 1, closed state tariff 2. Tariff 3 is not used at this case.

4.3.3.2 Maximum Demand Processing

From the instantaneous measured values of all active powers the instrument evaluates their average values per preset period using preset averaging method. Such quantities are called *actual demands (AD)*. Note that the actual demands are processed individually and their averaging method & period are presettable independently on standard average values (P_{AVG}).

Their maximum values reached since the last clearing or during the *MD evaluation interval*, are called *maximum demands (MD)*.

Fig. 4.31 : Maximum Demand Setting



Parameters determining maximum demand processing can be set in the **Setting – AVG – MD** screen. As default, the *floating window* averaging method is set.

The demand registered since the last clearing is marked simply **MD**. The demands registered during the *MD evaluation interval*, are marked with additional appropriate index X - see below.

The MD evaluation interval can be set in range 1 day up to 1 year.

The maximum demands are stored including their time stamps. They can be cleared independently of standard average maximums & minimums. Time & date of the last clearing can be checked in the MD-

setting screen.



After the MD average parameters set or registered MD values cleared, evaluation of demands starts from beginning. The demand values are temporary not available until the first averaging window expires.

4.3.3.2.1 Fixed Window MD Processing, Last Demand and Estimated Demand

If the maximum demand averaging mode is set to the *fixed window* method, evaluation of the **AD** is different from that of floating window. Auxiliary energy buffer is cleared at the beginning of every averaging window and starts to count from zero. So average power that is calculated from energy registered in the buffer divided by averaging window length drops to zero periodically, then raises and reaches true average power at the end of the averaging interval only.

Then other demands can be useful :

- **LD** ... last demand = value of the **AD** (actual demand =average active power) at the end of previous averaging window. The value is displayed including its time stamp, that corresponds to the end of the window
- **ED** ... estimated demand = estimated value of the **AD** (actual demand =average active power) that should be reached at the end of current averaging window



If the maximum demand averaging mode is set to the *floating window* method, the **LD** and **ED** values are irrelevant (contains only copies of the **AD** quantities).

4.3.3.2.2 Maximum Demand Presentation

While in the electricity meter energy window you can switch down to the maximum demand windows.

The first branch has two screens only and comprises three-phase values :

- **3MD** ... maximum demand = maximum of **3AD** reached since the last clearing
- **3MD_{Lx}**, **3MD_{Cx}** ... maximums of the **3AD** reached during the last (**L**) and current (**C**) evaluation interval. The "X"-index depends on *the MD evaluation interval* preset value : D=day, W=week, M=month, Q=quarter, Y=year.
- **3AD**, **3LD**, **3ED** ... actual / last / estimated demand

Fig. 4.32 : Maximum Demand Screen Map

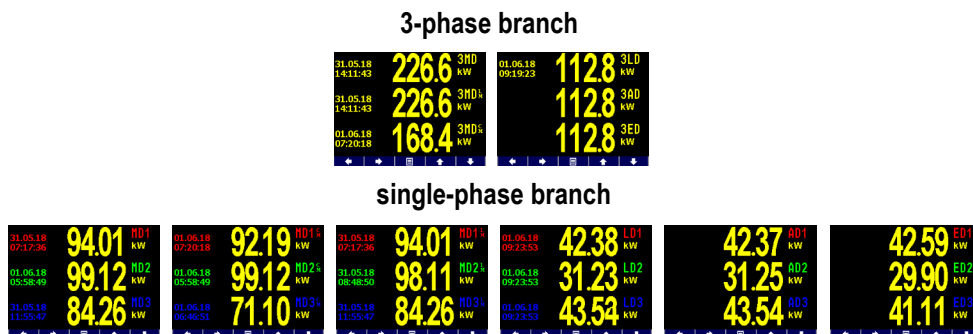

Scrolling down you get into the single-phase branch of the maximum demand values. You can check individual phase demands here.

4.4 Embedded Auxiliary Voltage Backup (SMP 133 only)

Internal power supply of the SMP 133 instruments is equipped with the supercapacitor backup module. With this module, measurement core of the instruments can operate continuously even at short auxiliary power outages (see technical specifications for backup times).

Only voltage & current measurement core and the Ethernet interface are backed up, so following devices are unfunctional during the backup :

- display
- digital inputs & outputs
- communication interfaces but the Ethernet
- auxiliary voltage for current sensors at „X/333mV“ and „FLEX“ models

5. Residual Current Monitoring (RCM)

Instruments equipped with residual current inputs can be used for residual current monitoring (RCM). The RCM can get early warning of measured network failures.

The instruments measure alternating and pulsating direct residual currents according to the A-type RCM specification as defined in the IEC 62020 standard. No directional sensitivity of the residual currents is implemented.

5.1 Measuring Transformers for the RCM

All of the instruments are designed for indirect connection, thus use of a current transformer is necessary. But for the RCM, special residual current transformer (RCT) must be used. The following parameters are essential for a suitable RCT selection :

- **In** ... rated current = maximum primary current of the RCT. The RCT **In** must be greater than the upstream circuit breaker rating (= maximum permanent phase current of monitored network). If not specified, the RCT **Icth** (rated continuous thermal current) can be used instead.
Usually, size of the RCT and its window depends on the **In** value – check it too in order the cable used to match it.
- **RCT-ratio** ... (600/1, for example)
- **IΔn** ... primary residual operating current. It defines range of primary residual currents that can be measured with defined accuracy and used for reliable indication of a residual current threshold exceeding. Then :
 - desired residual current threshold must fit into the RCT **IΔn** range
 - the desired residual current threshold divided by the RCT-ratio must fit into the instrument residual current range
- **RRCMMAX** ... maximum burden = maximum impedance of the shunt connected to the RCT output. It must be higher than the instrument residual current input impedance.

5.1.1 Electrical Safety

The residual current measurement inputs are not isolated from the instrument internal circuitry, therefore signals of safe voltage only can be connected to.



Insulation of used RCT must fulfil IEC61010-1 requirements for the CATIII double insulation for the mains voltage present!

5.1.2 Standard RCTs with AC-Current Output

These RCTs are commonly used. Appropriate **CT_{RCM}**-ratio in form xxx/1 must be set in the *Installation* group of parameters.

But it must be taken in account that in certain cases possible overcurrent on the RCT output could be dangerous for the instrument input.

5.1.2.1 Overcurrent Protection

Unlike standard current inputs, the residual current inputs are designed to measure residual current in range of milliamperes (see technical specifications), i.e. currents that are several orders of magnitude

lower. Due to this, they are generally less resistant against overcurrents than the standard current inputs.

Therefore, check possible worst conditions in the network and calculate maximum possible residual currents on the RCT output, both the permanent and the dynamic ones. Then compare them with maximum allowable static and dynamic currents of the instrument inputs that can be found in technical specifications.

Particular care must be taken during the RCT installation. When, for example, only two power conductors of a three phase cable is installed into the RCT by mistake, the RCT can push from its output false residual current of magnitude corresponding up to rated phase current of the network!

Example :

rated nominal primary phase current :	120 A
RCT-ratio :	600 / 1
false primary residual current (2 phase currents only measured):	120 A
false secondary residual current :	$120 / 600 = 0.2 \text{ A}$



If the RCT is powerful enough to source such false secondary residual current for long time and its value exceeds maximum allowable current of the instrument input, it is strongly recommended to check the RCT output current before connecting it to the instrument!



Never use standard CTs with 5A nominal secondary current for the RCM! Eventual overcurrent could damage the instrument residual current input!

5.1.3 Special RCTs with DC-Current Output

Besides standard RCTs, RCTs with output current loop of 4-20 mA DC can be used too. In such case, instead the CT_{RCM} -ratio set primary residual current values corresponding to 20 mA in the *Installation* group of parameters (see below).

Any current overload of the instrument inputs cannot occur in such case.

5.2 RCM Inputs Connection

Although it is not mandatory, we recommend to connect the S1-signal (or "k") from a standard type RCT to the **IA11 / IA21** terminal and the S2-signal ("l") to the **IA12 / IA22** when standard RCT is used.

When special RCT with DC current loop output used, connect positive (+) pole to the **IA11 / IA21** terminal and negative pole (-) to the **IA12 / IA22**.

recommended wire type :	H05V-U (CY)
recommended minimum cross-section :	0.5 mm ²
maximum cross-section :	1.5 mm ²



Check measured residual currents immediately after the RCT connection - if any is higher than maximum allowable current of the input (defined in the technical specifications), disconnect the RCT immediately, otherwise the instrument can be damaged!!!

Residual currents are marked $I\Delta$ and can be checked on the instrument display. When any of the RCM inputs is overloaded, the indicator flashes at the display upper right corner.

Then set the CT_{RCM} -ratio in the *Installation Setting* group of parameters.



The RCM inputs are isolated neither from instrument internal circuitry nor mutually! The terminals $I\Delta 12$ and $I\Delta 22$ are connected internally, do not connect signals of different potential to them!



One of outputs of each RCT can be optionally grounded to PE – in such case, always ground the output connected to the $I\Delta 12$ / $I\Delta 22$ terminal(s)! Take such grounding in account when one of residual current inputs is used for the RCM and simultaneously the other one for a 20 mA DC current loop measurement or when a temperature input is connected too to avoid possible short-circuits!



Maximum length of cable is 3 meters ! Otherwise, EMC-immunity of the instrument can be degraded.

5.3 RCM Setup & Presentation

If a standard RCT with AC-current output is used, set its CT_{RCM} -ratio in the *Installation* group of parameters. Optionally, you can use the I_{RCM} -multiplier too.

Fig. 5.1 : Standard RCT CT_{RCM} -Ratio and I_{RCM} -Multiplier Setting

Setting - Installation	
VT Mode	direct
Connection	3Y
U-Mult.	1.00
CT	500 / 5
I-Mult.	1.00
CTN	300 / 5
IN-Mult.	1.00
RCT Ratio	600 / 1
IRCM-Mult.	1.00

Fig. 5.2 : DC-Current Output RCT Ratio Setting

Setting - Installation	
VT Mode	direct
Connection	3Y
U-Mult.	1.00
CT	500 / 5
I-Mult.	1.00
CTN	300 / 5
IN-Mult.	1.00
RCT Curr.	300 / 20mA
RCT type	4-20mA

If a RCT with DC-current output loop 4/20 mA or 0/20 mA is used, switch appropriately the **RCT type** first by editing the I_{RCM} -multiplier. Then enter the RCT primary current corresponding to 20 mA DC output (in milliamperes – on the example above conversion ratio of 300 mA / 20 mA is set). The value corresponding to 0 or 4 mA cannot be set – it is supposed zero automatically.

Effective values only of residual currents are available. The residual currents are marked as $I\Delta 1$ and $I\Delta 2$.

The residual current values can be not only monitored and archived, but exceeding a preset level can be signalled using appropriate I/O Setup condition – see appropriate chapter below.



If the **0-20mA** or the **4-20mA** RCT type is set, residual current value is marked as overloaded and the indicator flashes at the display upper right corner as soon as the primary residual current exceeds the value corresponding to secondary current of 20 mA, indicating possible overload of the RCT.



*If the **4-20mA** RCT type is set, residual current value is marked as possible wrong and the indicator  flashes at the display upper right corner as soon as the RCT secondary current drops below 3.8 mA, indicating wrong connection or possible damaged RCT .*



As soon a residual current input is used as analog input (AI) and corresponding action is defined in the I/O block setup (see below), residual current monitoring on appropriate input is suppressed and appropriate $I\Delta$ value is no longer available!

5.4 Tips & Hints

- Never lead the PE conductor through a RCT, only **all live conductors** can be threaded through. The only exception is when residual current is monitored by a single PE conductor measurement – then it must be **the only conductor** threaded through.
- Never lead a shielded cable through the RCT.
- Install the RCT on straight part of a cable, far enough from bends. Center the cable inside the RCT window as precise as possible. Otherwise, false residual currents may appear.
- To reach higher immunity to false residual currents due to asymmetric installation, especially when low residual currents to be measured, use a RCT with a larger window diameter than is necessary.
- Take in account native leakage currents caused by long cables (stray capacitance), capacitive filters, surge arresters, etc., especially when many single-phase appliances connected to the PE-conductor (for safety or other purposes) installed in the monitored network. They can cause nuisance residual current indication.

6. Inputs & Outputs

Instruments can be optionally equipped with a combination of outputs and inputs (see manufactured models marking below). Following I/O types are available :

- electromechanical relay digital output, referenced as **ROx** (x =output number)
- solid state (semiconductor) digital output – **DOx**
- digital signal input (solid state) – **DIx**
- analog input , usually of range 0-20 mA_{DC} – **AIx**
- temperature input, usually for a Pt100 sensor – **TE**

Depending of instrument model following inputs & outputs are available :

I/O Combination Assortment

model	I/O combination	I/O character
RR	2 x RO + 1 x DI	bipolar (AC/DC)
RI	1 x RO + 1 x DO + 1xDI	bipolar (AC/DC)
II	2 x DO + 1 x DI	bipolar (AC/DC)
V	4 x DO/DI (bidirectional)	unipolar (DC)
W	2 x RO + 2 x DI	bipolar (AC/DC) bipolar (DC)
AA	1 x DO/DI (bidirectional) 2 x AI	unipolar (DC) 20mA DC loop (shared with RCM)
AT	1 x DO/DI (bidirectional) 1 x AI 1 x T _E	unipolar (DC) 20mA DC loop (shared with RCM) Pt100
DT	2 x DO/DI (bidirectional) 1 x T _E	unipolar (DC) Pt100, isolated

All of the „RR / RI / II“ models have 2 digital outputs and 1 digital input. Both outputs and input are bipolar, i. e. signal polarity is free and even AC signals can be switched and read.

By contrast, the „V“ models have 4 digital inputs/outputs and any of them can be used as either input or output. The signal polarity must be kept ; it depends on whether particular I/O is used as input or output (see description below).

The „DT“ models have two digital inputs/outputs equal to the „V“ models and on the next 3 pins there is a Pt100 temperature sensor input for an external temperature (T_E) measurement.. The input is isolated from instrument internal circuits.

The „W“ models have two electromechanical relay outputs (so marked as RO1 and RO2) and two bipolar digital inputs (DI1, DI2).

The „AA“ and „AT“ models have 1 digital input/output of the same features as that of the „V“ models. Next, depending of the model, they have either 2 or 1 residual current input(s), that – if not used for residual current measurement - can be used as 0-20mA DC (or 4-20mA DC) current loop analog input. The „AA“ models have two such inputs, the „AT“ models only one. Instead of the second one, the „AT“ models have a Pt100 temperature sensor input for an external temperature (T_E) measurement. Both these analog and temperature inputs are not isolated from instrument internal circuits.

Furthermore, all of instrument models feature two “alarm ” lights **A1** and **A2** for indication of various states, that can be considered as other special digital outputs. Function of these lights can be set in the same way as at standard digital outputs.

The behaviour of digital outputs can be programmed according to requirements as :

- *standard output* ... a simple two-position controller or a defined status indicator
- *pulse output* ... transmitting electricity meter (only DO-type outputs)
- *time synchronization output* ... for transmission of second or minute pulses

Digital inputs can be used :

- for *state monitoring* (a contact closure etc.)
- as *pulse or frequency counter* (see description below)
- as input quantity of *an I/O setup clause condition* (see description below)

Actual state of both alarm lights and digital I/Os can be checked on the status bar (see above).

6.1 Connection of the I/Os

The I/O connector is situated in the bottom right corner.

Fig. 6.1 : SMY133/134 – Connectors

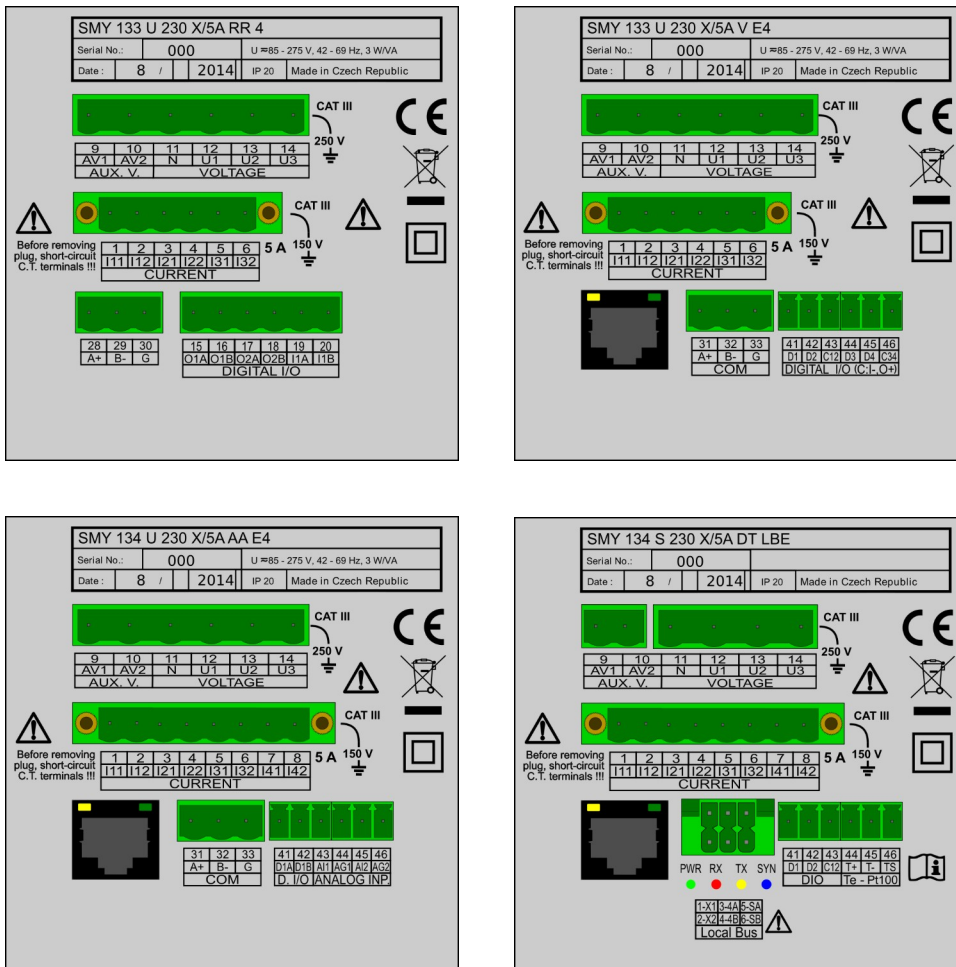

Inputs & outputs are connected to terminals on a rear panel of an instrument according to the following tables.

RR / RI / II Models – I/O Connection

terminal No.	signal	notes
15, 16	O1A, O1B ... DO1/RO1 digital output	- input and outputs are isolated both from instrument internal circuitry and mutually recommended wire type : H05V-U (CY) rec. minimum cross-section : 0.75 mm ² maximum cross-section : 2.5 mm ²
17, 18	O2A, O2B ... DO2/RO2 digital output	
19, 20	I1A, I1B DI1 digital input	

V Models – I/O Connection

terminal No.	signal	notes
41	D1 ... DO1 digital output or DI1 digital input	- input and outputs are unipolar - common pole of outputs „DO“ is positive (+) - common pole of inputs „DI“ is negative (-) - inputs and outputs are isolated from instrument internal circuitry - DO1/DI1 & DO2/DI2 pair is isolated from DO3/DI3 & DO4/DI4 pair recommended wire type : H05V-U (CY) rec. minimum cross-section : 0.5 mm ² maximum cross-section : 1.5 mm ²
42	D2 ... DO2 digital output or DI2 digital input	
43	C12 ... DO1/DI1 & DO2/DI2 common pole	
44	D3 ... DO3 digital output or DI3 digital input	
45	D4 ... DO4 digital output or DI4 digital input	
46	C34 ... DO3/DI3 & DO4/DI4 common pole	

DT Models – I/O Connection

terminal No.	signal	notes
41	D1 ... DO1 digital output or DI1 digital input	- input and outputs are unipolar - common pole of outputs „DO“ is positive (+) - common pole of inputs „DI“ is negative (-) - inputs and outputs are isolated from instrument internal circuitry recommended wire type : H05V-U (CY) rec. minimum cross-section : 0.5 mm ² maximum cross-section : 1.5 mm ²
42	D2 ... DO2 digital output or DI2 digital input	
43	C12 ... DO1/DI1 & DO2/DI2 common pole	
45, 46, 47	T+, T-, Ts T_E Pt100 temperature sensor input	- isolated from instrument internal circuitry - three-wire or two-wire connection recommended wire type : H05V-U (CY) rec. minimum cross-section : 0.5 mm ² maximum cross-section : 1.5 mm ²

W Models – I/O Connection

terminal No.	signal	notes
41	RO1 ... RO1 digital output	- RO1 & RO2 : electromechanical relays, bipolar - DI1 & DI2 inputs are bipolar - inputs and outputs are isolated from instrument internal circuitry - RO1 & RO2 pair is isolated from DI1 & DI2 pair recommended wire type : H05V-U (CY) rec. minimum cross-section : 0.5 mm ² maximum cross-section : 1.5 mm ²
42	RO2 ... RO2 digital output	
43	CO RO1 & RO2 common pole	
44	DI1 DI1 digital input	
45	DI2 DI2 digital input	
46	CI DI1 & DI2 common pole	

AA / AT Models – I/O Connection

terminal No.	signal	notes
41, 42	D1A, D1B ... DO1 digital output or DI1 digital input	- digital input/output is unipolar - D1B of output „DO“ is positive (+) - D1B of input „DI“ is negative (-) - digital I/O is isolated from instrument internal circuitry recommended wire type : H05V-U (CY) rec. minimum cross-section : 0.5 mm ² maximum cross-section : 1.5 mm ²
43, 44	IΔ11, IΔ12 ... IΔ1 residual current input or ... A11 20mA loop analog input	- for residual current IΔx1 is S1 (k) - for 20mA loop IΔx1 is positive (+) - inputs are not isolated from instrument internal circuitry !!! - the same signal (voltage level) or potential-free signal can be connected to the terminals IΔ12, IΔ22 or T- only !
45, 46 AA*)	IΔ21, IΔ22 ... IΔ2 residual current input or ... A12 20mA loop analog input	
45, 46 AT*)	T+, T- T_E Pt100 temperature sensor input	recommended wire type : H05V-U (CY) rec. minimum cross-section : 0.5 mm ² maximum cross-section : 1.5 mm ²

Note : AA*) ... valid pro the „AA“ models only; AT*) ... valid pro the „AT“ models only

6.1.1 Digital Output (DO, RO) Connection

The outputs are accomplished by a semiconductor switching device (DO) or an electromechanical relay (RO). Maximum allowable voltage and load current according technical specifications must be observed.

The signal polarity for the „V“, „DT“, „AA“ and „AT“ models must be kept according the table above. For the „RR/RI/II“ and the „W“ models, it is free.

The outputs are isolated from instrument internal circuitry. For the „RR / RI / II“ models, they are isolated mutually too. For other models, each output pair has common pole and the pairs are isolated mutually.

6.1.2 Digital Input (DI) Connection

The input supposes a voltage signal of appropriate magnitude is connected (see technical specifications). The signal polarity for the „V“, „DT“, „AA“ and „AT“ models must be kept according the table above. For the „RR/RI/II“ and the „W“ models, it is free.

If the voltage exceeds declared level, the input is activated (=value 1).

Usual 12 or 24 V DC/AC signals can be connected directly. If you need to connect a voltage signal of magnitude exceeding maximum digital input voltage, external limiting resistor of appropriate rating must be used.



Any of the „V“, „DT“, „AA“- and „AT“-type digital inputs can be used as output too. When used as input there must not be set output function on the same terminal. Furthermore, proper polarity of signal terminal and appropriate common terminal must be kept.

The digital inputs are isolated from instrument internal circuitry.

For the „RR / RI / II“ models they are isolated from outputs too. For other models, each output pair of inputs/outputs has common pole and the pairs are isolated mutually.

6.1.3 Analog Inputs Connection

If residual currents are not measured, the residual current inputs can be optionally used as 0-20mA DC (or 4-20mA DC) current loop analog inputs.

Check if the signal source is capable to work with the impedance of the input defined in the technical specifications.

Connect positive signal (+) to the **IA11 / IA21** terminal and negative signal (-) to the **IA12 / IA22**.

Then set the input parameters – see the chapter *I/O Setup* below.



The residual current inputs and external temperature input of „AA“ and „AT“ models are isolated neither from instrument internal circuitry nor mutually ! The terminals IA12 and IA22 (or IA12 and T- for the AT-model) are connected internally, do not connect signals of different potential to them !



For „AA“ and „AT“ models, maximum length of the cable is 3 meters. Otherwise, immunity against electromagnetic disturbances can be affected negative !



As soon an analog input (AI) mode is activated in the I/O block setup (see below), residual current monitoring on appropriate input is suppressed and appropriate IA value is no longer available !

6.1.4 External Pt100 Temperature Sensor Connection

With „DT“ and „AT“ models, an external temperature T_E can be measured. Corresponding input of this model is designed for connection to a Pt100 resistive temperature sensor.

6.1.4.1 „DT“ Models

The input is designed for three-wire connection to a resistive temperature Pt100-type sensor. Connect the sensor to the terminals No. 44 (**T+**), 45 (**T-**) and 46 (**TS**) according example drawing below.

In case of two-wire connection, connect the sensor to the terminals **T+** and **T-** and short-circuit the **T-** terminal with the **TS** terminal.



In case of two-wire connection, note that the sensor cable loop impedance must be as low as possible - each 0.39 Ohms means additional measurement error of 1 °C !

6.1.4.2 „AT“ Models

Connect the sensor to the terminals No. 45 (T+) and 46 (T-).



If any signal is connected to the IΔ11 - IΔ12 inputs too, note that IΔ12 terminal is connected with the T- terminal internally. So mutually isolated signals or signals with the same common pole potential can be connected only !



For „AT“ models, maximum length of the cable is 3 meters. Otherwise, immunity against electromagnetic disturbances can be affected negative !

6.2 I/O Setup

The inputs and outputs processing capabilities are very wide and it would be rather complicated to set it using the instrument panel. Therefore, you can set it only on a PC connected with a communication link only using the ENVIS-DAQ program.

Fig. 6.2 : The I/O Management Setup Example in the ENVIS-Daq Program

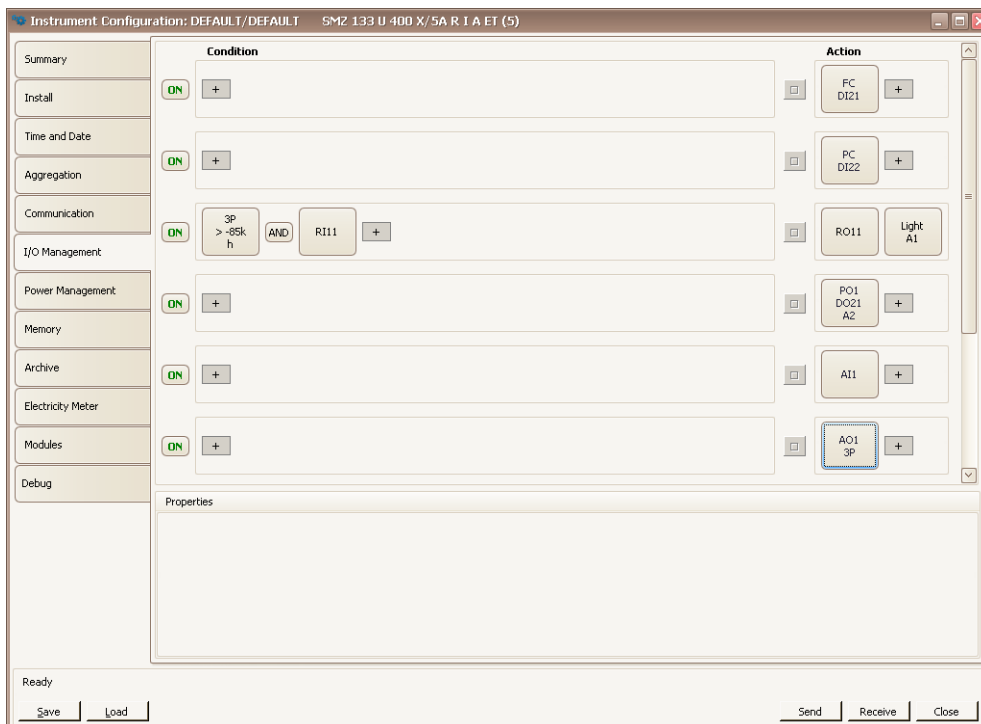



For

the I/O setup, use *Config* → *I/O Management* . Complete I/O setup consist of so called *clauses* . Individual clauses are listed in the I/O management screen.

Each clause consists of :

-  ... *The clause switch* - If ON the clause is active, i.e. *the clause condition* (if any set) is evaluated and if it gets true (= logic 1), *the clause action* (or actions) are processed. By clicking on the switch you can toggle it to OFF – then the clause processing is suppressed and has no effect.
- *The clause condition* – a logic expression. When result of the expression is true (= logic 1) the clause action is performed. If the result is false (= logic 0), the action is not performed (=suppressed).

The clause condition can :

- be empty – then appropriate clause action is performed permanently (empty condition gets true result)
- be created by one condition item only (for example *the quantity value condition*)
- be formed by combination of two or more *condition items* joined with  and  operators (see the clause No. 2 in the example above)
- *The clause action* – with the actions you can set various functions concerning usually instrument inputs and outputs. Typical action are, for example, a digital output control or an analog input processing.



The symbol  is neither condition, nor operator nor an action – it is the button with which you can add conditions or actions into the clause.

Even if no I/O action is set the I/O Management folder contains one empty clause “template“ with the -buttons prepared for new clause definition.

To add new clause, click on the -button in the action (= right) field of an empty clause template. In the pop-up menu choose required action. You can add either one or up to two actions into the same clause.

Optionally, you can add one or more conditions too with corresponding -button in the condition (=left) field. If more conditions added, you must set the logic operators OR/AND - simply click on it to toggle its value..



When designing the condition expression, note that the AND operator has higher priority - firstly, subexpressions joined with the AND-operators are evaluated and then the rest of the expression with the OR-operators.

To remove an action or a condition from a clause, click on it and press the *Delete* button in the condition/action properties field (or push the *Delete* key).

For temporary disabling or enabling any of the clauses use the ON / OFF clause switch. When OFF, the clause operation is suppressed, but it stays in the setup prepared for future use.

6.2.1 I/O Actions

6.2.1.1 Digital Output (Standard, DO/RO)

In combination with a suitable condition (see *the quantity value condition* description below) you can create simple two-state controller or indicator with this action. This type of action will be called as *standard output*.

Add *the Digital Output* action and set :

- desired *digital output*

- *polarity* ... choose *Direct* if the output to be switched on under true result of corresponding clause condition and vice versa
- *control* ... when set to 1 the output state simply follows the condition result value. If set to \uparrow the output switches on/off (depending on the polarity setup) temporary for preset *pulse width* only when the condition result changes from *false (0) to true (1)*

Fig. 6.3: I/O Setup – Standard Digital Output Action Properties

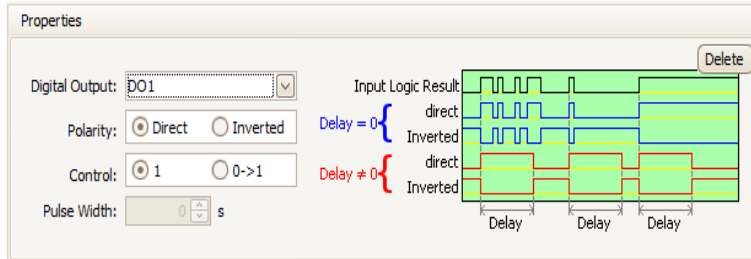

For simple „manual“ control of a digital output add the standard digital output action without any condition („empty“ condition gets permanent true (=1) result). Then set desired polarity and send the setup into the instrument..

6.2.1.2 Alarm Light (A)

Alarm lights A1, A2 can be set in the same way as digital outputs (see above) and used for indication of various events on the instrument display.

6.2.1.3 Pulse Output (PO)

Any of digital outputs or alarm lights can be set as transmitting electricity meter. The frequency of generated impulses can be set depending on values of measured electric energy by the embedded electricity meter unit.



You can set to impulse output mode not only the **I**-type (solid-state) outputs, but the **R**-type (electromechanical relay) outputs too. But note lifetime of electromechanical relays, they have limited number of switching operations.

For pulse output following parameters must be set :

- target *digital output*
- target energy quantity ... the transmitted energy must be chosen here (see the electricity meter description for the energies explanation)
- number of *pulses per kWh/kvarh/kVAh*

Fig. 6.4: I/O Setup – Pulse Output Action Properties

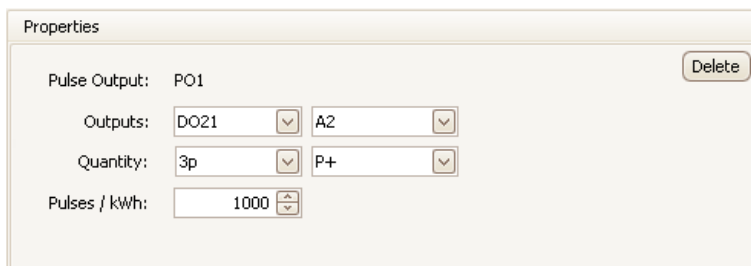



You can set one of alarm lights (A1, A2) as pulse output too and then you can check the pulse function on the instrument display simultaneously.

6.2.1.4 Pulse Switch (Switch)

The pulse switch action is designed to control switches or contactors that require two signals : one for switch-on and the second for switch-off.

Select digital outputs for switch-on and for switch-off and set the switching pulse width. Next add a condition for the pulse switch action.

Fig. 6.5: I/O Setup – Pulse Switch

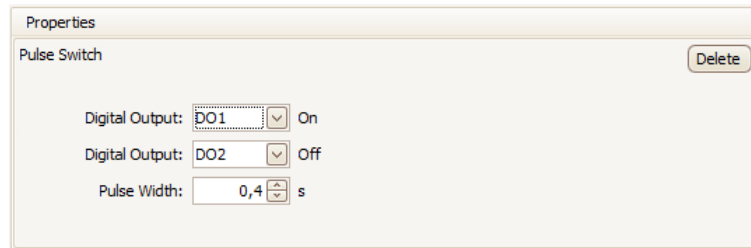

Properties
Pulse Switch Delete

Digital Output: DO1 On

Digital Output: DO2 Off

Pulse Width: 0,4 s

After the setup, if any change of the condition occurs, pulse of specified duration appears :

- on the output set as *On*, when false-to-true change
- on the output set as *Off*, when true-to-false change

6.2.1.5 Frequency Counter (FC)

The digital input can be used for monitoring of a quantity depending on frequency or duty cycle of incoming pulses.

6.2.1.5.1 Frequency Mode

As example, flowmeters or anemometers with pulse output (often the „S0-type“) can be connected and the instrument can measure and record a flow rate or a wind speed. So despite being so called, this quantity is not any counter but a frequency controlled quantity.

Select an empty clause and add the *Frequency Counter* action. In the *Type* field choose *Frequency*. In the *Properties* field below you can set :

- *name* of the quantity (for example *Vwind*)
- *unit* of the quantity (*m/s*)
- transformation ratio in one of two formats :
 - either *Hz / Unit* ... frequency of the input pulses in hertzs corresponding to one unit
 - or *Units / Hz* ... value of the quantity (in the set units) in case the input pulse frequency is 1 Hz

Fig. 6.6 : I/O Setup – FC Action Properties

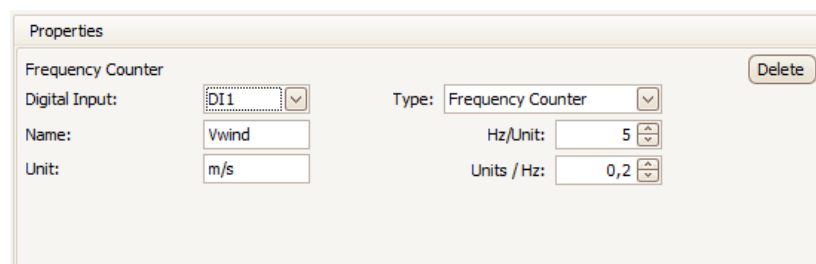

Properties
Frequency Counter Delete

Digital Input: DI1 Type: Frequency Counter

Name: Vwind Hz/Unit: 5

Unit: m/s Units / Hz: 0,2

If the name is not defined, the quantity is referenced with its general name *FCxx* (when the *xx* is index of corresponding digital input).

6.2.1.5.2 PWM Mode

In this mode the duty cycle of incoming signal controls the counter value. Such signal is often called *PWM* (Pulse With Modulation) too.

In the *Type* field choose *PWM*. The other settings are the same as that of *Frequency* type excluding the transformation ratio – it is specified with limit values for duty of 100% (permanently active input) and 0% (permanently inactive input).

6.2.1.6 Pulse Counter (PC)

Similarly, counters of incoming pulses can be checked for all of digital inputs. The counters usually represent amount of a media passing since last counter clearing.

Add the *Pulse Counter* action and set :

- *name* of the counter (for example *Barrel1*)
- *unit* of the quantity (*hl*)
- transformation ratio in one of two formats :
 - either *Pulses / Unit* ... number of the input pulses corresponding to one unit
 - or *Units / Pulse* ... value of the quantity (in the set units) corresponding to one pulse

Fig. 6.7 : I/O Setup – PC Action Properties



If the name is not defined, the quantity is referenced with its general name *PCxx* (when the *xx* is index corresponding digital input).

6.2.1.7 Analog Input (AI)

For each of the analog inputs there must be specified :

- *analog input* number
- represented quantity *name*
- represented quantity *unit*
- input type and *conversion ratio* ... choose either "10V" or „20mA" input type and the values of represented quantity for 10V / 20mA and 0V / 4(0)mA, respectively

Fig. 6.8 : I/O Setup – Analog Input Properties

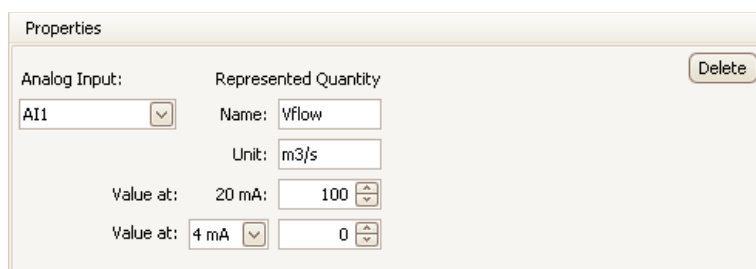



If an analog input is capable to measure residual current too, appropriate $I\Delta$ residual current is measured on the input as default, using the CT_{RCM} ratio specified in the Installation group of parameters.

But as soon as the analog input action is defined in the I/O block setup, the residual current monitoring on this input is suppressed and appropriate $I\Delta$ value is no longer available, because the input is used for a 20 mA current loop signal now.

6.2.1.8 Analog Output (AO)

Analog outputs require following parameters to be set :

- *analog output number*
- *control quantity & phase ...* select desired quantity to be transmitted to the output. Both single-phase and three-phase quantities or logical AND/OR of them can be chosen.
- *conversion ratio ...* values of control quantity corresponding to 20mA and 4(0)mA

Fig. 6.9 : I/O Setup – Analog Output Properties

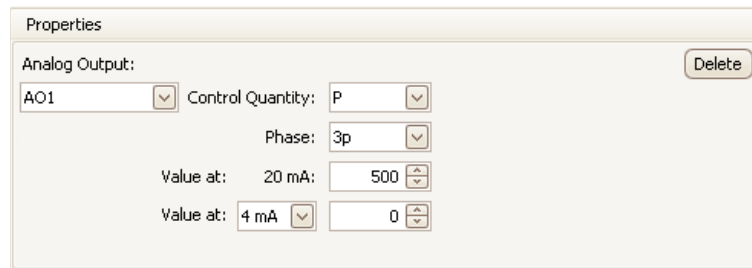

If the conversion ratio is defined with the 4/20 mA form, output current never drops under 4 mA – this minimum output current is kept even if corresponding control quantity is lower in order to supply possible passive receivers connected.

Output current is limited to maximum value of 22 mA.

6.2.1.9 Send Message (Message)

With this action a simple message can be transmitted to chosen communication interface. The message must be entered in hexadecimal format.

The message is sent as soon as corresponding condition changes from false to true. With the *Repetition* option, you can set multiple transmissions of the message.

Fig. 6.10 : I/O Setup – Send Message

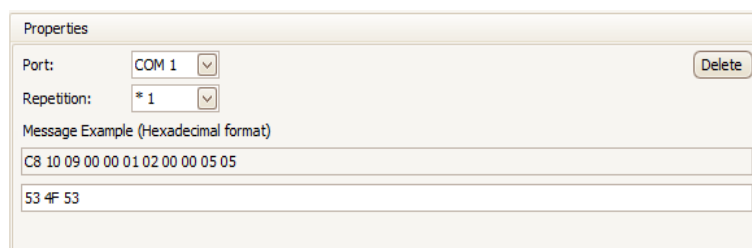



Target port can be set not only to any of the instrument ports, but to **SELF** too. Then the message is not transmitted, but it is processed inside the instrument itself in the same way as incoming command in Modbus format. It can be used in special cases for instrument setup change.

6.2.1.10 Send Email

Similar function as the previous action. Besides the message you can set the message *subject* too - both in text format.

Fig. 6.11 : I/O Setup – Send Email

Furthermore, recipient must be specified in the *Communication* setup folder. Enable the *Email* option and set email parameters according application note No. 003 : *E-mail Usage for Status Notifications* .

Fig. 6.12 : Communication Setup Example for the Send Email Action

6.2.1.11 Show Note (SN)

With this action a simple note can be displayed on the instrument display. It can be used for various alerts or warnings of the instrument operator.

Add the *Show Note* action and fill the *Note* field, for example:

Fig. 6.13 : I/O Setup – Show Note



Th

The note is any text string. Due to limited space on the display, it can be about 60 characters long at maximum.

Then – for the first testing – check the *Show Note Screen* checkbox, let the clause condition empty and send the setting into the instrument. Function of the checkbox will be explained later below.

Now, if the action was added into a clause without any condition, it is permanently active (because value of empty condition is true=1). This should be reflected in flashing note indicator  on the instrument display.

The indicator signals that at least one unconfirmed note is displayed in the *Note* user screen. To view a note, the Note user screen must be added into the main data group (see the *Main Data Group* chapter above).

After the *Note* user screen added, the screen should be displayed immediately. It contains :

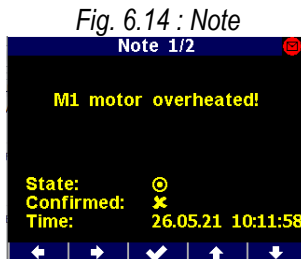





Fig. 6.14 : Note

- **Note 1/2** ... it means that note No. 1 of the total number of two notes is displayed now. You can list through all of notes with buttons



- **Note text** ... can have up to three rows

- **State** ... condition of the note actual value (active now)

- **Confirmed** ...  = the note not yet confirmed. You can confirm reading of the note with the  button. Then the value changes to , the note gets „passive“ and it stops notification indicator initiating.

- **Time** ... note timestamp: date and time the note was generated

Now you can add appropriate condition into its clause and start using it.

If the *Show Note Screen* feature is not checked in the note setting in the I/O setup, the note initiates notification indication with the  indicator only. To check such note, it is necessary to scroll to the note screen manually.

If the *Show Note Screen* feature is checked, the note (besides the notification indication) is automatically displayed.



The mechanism of automatic note display is temporarily suppressed for about one minute after the last pushing of any button to enable manual scrolling between screens.

As soon as a note is confirmed, it gets „passive “. Then it causes notification indication and automatic display no more, even if the note condition (=State) remains true (=1).

The note can be „reactivated“ only when its condition changes to false (=0) and then to true again. Then the note gets active (=unconfirmed) again. Simultaneously, the note timestamp is updated.

At least 8 various notes marked from 1 to 8 can be set in the I/O setup (it depends on length of the notes).

6.2.1.12 Hour Meter (HM)

With the hour meter it is possible to measure duration of some events. Add the hour meter and enter its name – HX2, for example:

Fig. 6.15: I/O Setup – Hour Meter

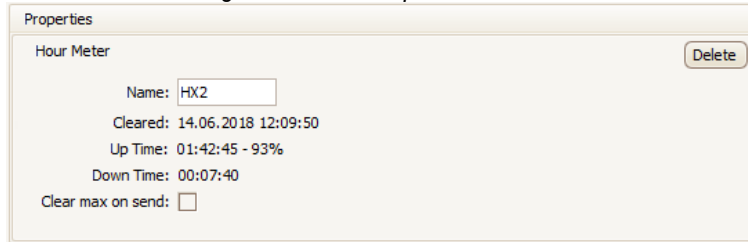

Th

Then add a condition for the event - for example, for checking of time of power overload, add the *Measured Quantity* condition and set a power limit for it (see condition setup below).

After that, the hour meter starts running. It contains three counters :

- **Up** ... the period since the last clearing for which the condition was met (= true)
- **Down** ... the period since the last clearing for which the condition was not met (= false)
- **Cnt** ... number of the condition false to true changes since the last clearing

Fig. 6.16 : Hour Meter

Hour Meters HM			
Up	h:m	Down	Cnt
HX1	22:19	0:35	4
HX2	1:42	0:05	2

Up to 4 hour meters can be defined.

To check state of hour meters on an instrument display, you must add the hour meter screen with the ENVIS-DAQ program into the main data group. Then you can scroll to the screen and check measured data.

On the example you can see two hour meters : HM1 with name HX1 a HM2 with name HX2. Duration of the *Up* and *Down* counters is expressed as *hours:minutes*.



The only method how to clear a hour meter is to select the hour meter setup icon in the ENVIS-DAQ program, check the option **Clear on send** and send the setting into the instrument. The time & date of the clearing is registered simultaneously and can be checked by reading the setting back from the instrument.

6.2.1.13 Time Synchronization (PPM/PPS)

Instruments that have internal real time counter (RTC) can be used for time synchronization of other instruments using this action.

Select digital output where the synchronization pulse to be sent to and choose the transmitting period to PPS or PPM. The synchronization pulse width is fixed : 200 ms.

Fig. 6.17 : I/O Setup – Time Synchronization Output

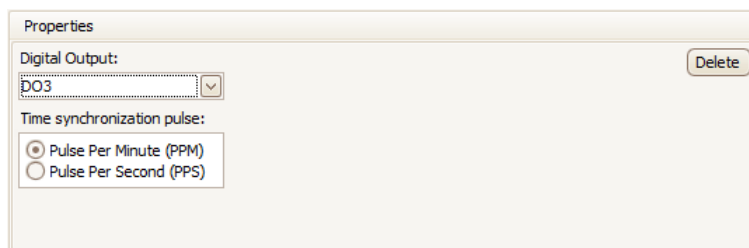

6.2.1.14 Archive Control

With this action you can control recording of measured data into the instrument archive.

You can set one of two operating modes :

- *Continuous* ... data recording runs when corresponding condition is true and stopped when false
- *Duration* ... data recording starts as soon as corresponding condition changes from false to true; after the period defined in the field *Duration* expires, the recording is stopped; then waits for the next false->>true change of the condition

Fig. 6.18 : I/O Setup – Archive Control

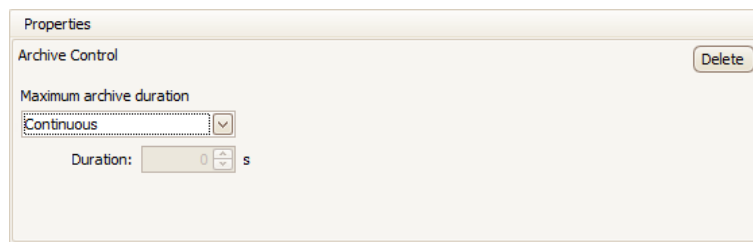

If no archive control action is set, the recording runs permanently.

6.2.1.15 General Oscillogram (GO)

This action is available when appropriate firmware module is installed only. It enables to record courses of measured voltages that can be displayed in graphical form.

In the setup screen you can set :

- voltage and current channels to be recorded
- sampling rate of recording :
 - **Adaptive** ... set 16, 32, 64 or 128 samples per period (**spp**)
 - **Fixed** ... set desired sampling frequency in Hz (**sps**)
- **Filter** ... check this option if signals of frequencies higher than that corresponding to sampling rate selected can occur in the network measured. If their magnitude is essential, distortion of oscillograms can occur due to alias effect.
- duration of record :
 - **Start** ... check **With condition** if recording to start just with the trigger; or check **Before condition** and set corresponding pretrigger part duration of the record
 - **End** ... check **With condition** or **After** and set corresponding posttrigger part duration

Fig. 6.19 : I/O Setup – General Oscillogram

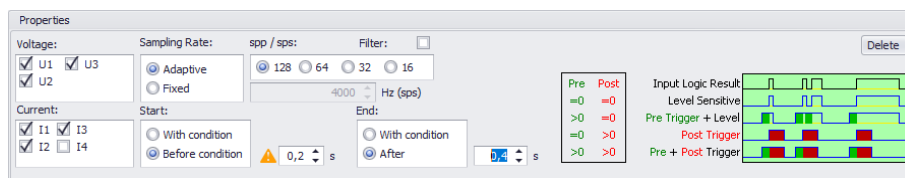

For further details see the application note *General Oscillogram Firmware Module* too.



Usually, the VE-All device state condition is optimal for the oscillogram record triggering. See the *Device State Condition* description below.



Check, if sufficient part of memory is allocated for the oscillogram recording in the memory setting folder ! Otherwise no records will be created !

6.2.1.16 Variable (Var)

With this action you can design more complex conditions in a clause than can be designed with basic conditions only.

Value of the variable is evaluated from the condition defined in the clause using the parameters below. Then it can be used in logic expressions of conditions in any of other clauses.

Add the action and choose its name *Var x*, where x is its serial number from 1 up to 16. Then set :

- *Polarity* ... if direct or inverted result of condition defined in the clause is used for the variable evaluation
- *Control* ... if the variable is the condition value controlled (1, "level-controlled") or the condition value change controlled (0→1, "edge-controlled")
- *Pulse Width* ... if the variable is edge-controlled (control = 0→1), this option defines the time for which the variable keeps true after being set to; then it gets back to false automatically
- *Persistent* ... as soon as the variable gets true this option "glues" the value until being reset back to false manually
- *Reset on send* ... if the variable keeps true due to the *Persistent* option, it is possible to force it back to false by checking this option and sending into the instrument

Fig. 6.20 : I/O Setup – Variable

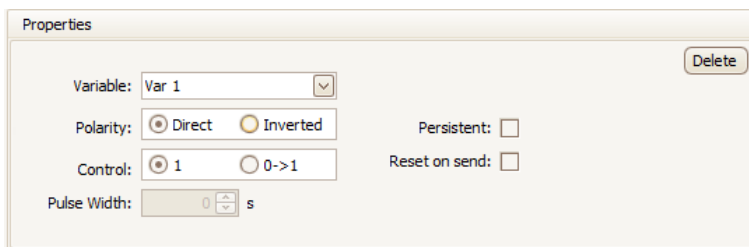

Now specify condition for this action, for example :

Fig. 6.21 : I/O Setup – Condition Example of the Variable Action

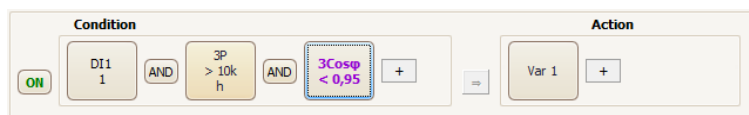

Then the variable is controlled by the condition and can be simply used in other clauses as another condition *Var1* - see the chapter *I/O Conditions* below.



During the I/O block initialization after the instrument power-up or restart, all of the variables (excluding that keeping true due to the *Persistent* option) are set to false. After each of the I/O block evaluation step, variable values are stored and used in the next step. See the *I/O Block Processing* chapter.

6.2.1.16.1 Variable Value Monitoring and Manual Change

Actual values of all of variables can be checked on instrument display with the *IO Variables* user screen (see *Main Data Group* chapter above).

Add the screen into the user selected screens and set :

- **screen name**
- at the list of variables :
 - add **variables** to be displayed. Each variable is clearly identified by its number
 - set the **variable name** – displayed variables are presented by their names, see below

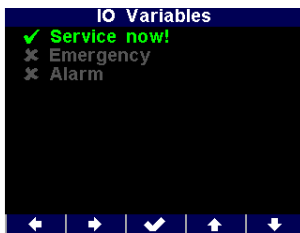

Then send the setting into the instrument.

Fig. 6.22 : *IO Variables* Screen





Now scroll through the *Main Data Group* screens and look the *IO Variables* screen up.

At the screen there is list of the I/O variables represented by their names. Current state of the variables is indicated with marks :

-  ... true (= logic 1)
-  ...false (= logic 0)



If a variable is edge-controlled you can manage it manually. With the  and  buttons select desired condition. Now by pressing the  you can toggle its value.

Note : If the variable is level-controlled, the I/O block process forces the variable value back to appropriate value immediately.

6.2.1.17 Send SNMP Trap (SNMP Trap)

The action can be used for notification of any event via IP network. So called SNMP trap can be send to one or more trap recipients.

Fig. 6.23 : *I/O Setup – Send SNMP Trap*

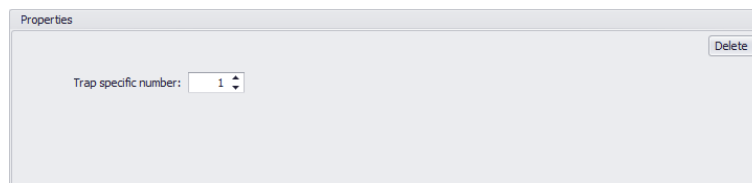

The *Trap specific number* is the only parameter you can set in the trap.

Recipient(s) must be specified in the *SNMP* block of parameters of *Communication* setup folder :

Fig. 6.24 : Communication Setup Example for the Send SNMP Trap Action

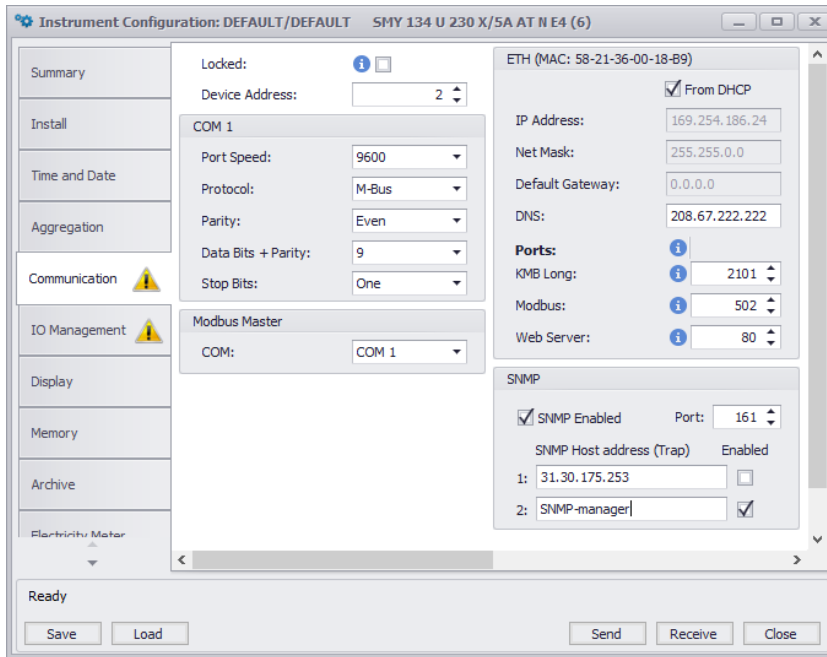

For

further detail see the *Simple Network Management Protocol (SNMP)* application note.

6.2.2 I/O Conditions

6.2.2.1 Digital Input Condition

Click on the -button in the condition part of target clause and choose the *Digital Input* option. Then you must set :

- desired *Digital Input*
- $1/0/0<->1/1<->0/0<->1$... state (=level controlled mode) or state change (=edge controlled mode) of the digital input that gets the condition *true* (logical 1). If any of state change set and the digital input keeps the same value as in the previous I/O block evaluation cycle the condition result is false.
- *Block Time* ... minimum duration of stable digital input state (relevant for level-controlled mode only). If not zero, quick changes of the input signal are “filtered” and new state of the condition result occurs only if the signal lasts for at least set block time. This setup is indicated with the “b” character in the condition icon.

Fig. 6.30 : I/O Setup – Digital Input Condition Properties

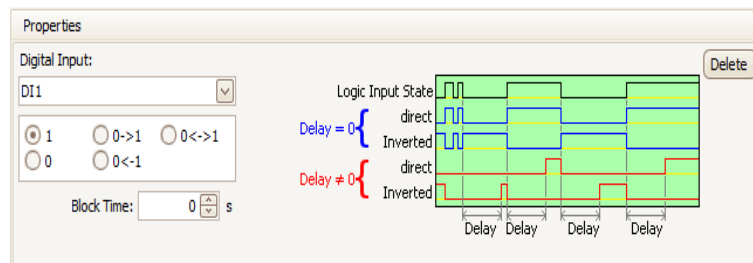

6.2.2.2 Measured Quantity Condition

Values of main measured quantities can be used as condition in the I/O setup clauses.

Fig. 6.31 : I/O Setup – Measured Quantity Condition Properties

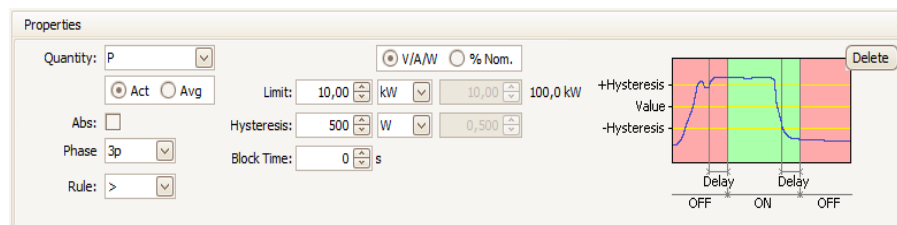

Selected quantity size is compared with preset limit and gets either true(1) or false(0) result. For this, the following parameters must be preset :

- *Quantity & Phase* ... desired control quantity (single- or three-phase or AND/OR combination of them)
- *Actual or Average* ... desired value of the control quantity
- *Abs* ... check if absolute value of control quantity to be evaluated (relevant for bipolar quantities only)
- *Rule* ... specifies polarity of deviation between the control quantity and the preset limit value for true result of the condition
- *Limit Value* ... limit value of the control quantity – either in basic units or percent of nominal value ($U_{NOM} / I_{NOM} / P_{NOM}$)
- *Limit Hysteresis* ... defines the insensibility range of the condition state evaluation

- *Block Time* ... defines minimum continuous duration of appropriate magnitude of control quantity until the condition result changes



If value of the control quantity is not defined result of the condition is false.

6.2.2.2.1 Condition Limit Checking and Editing on Instrument Display

All of measured quantity condition limit values can be checked on instrument display with the *I/O Limits* user screen (see *Main Data Group* chapter above).

Look on the I/O setup example below :

Fig. 6.32 : I/O Setup – Measured Quantity Condition Example

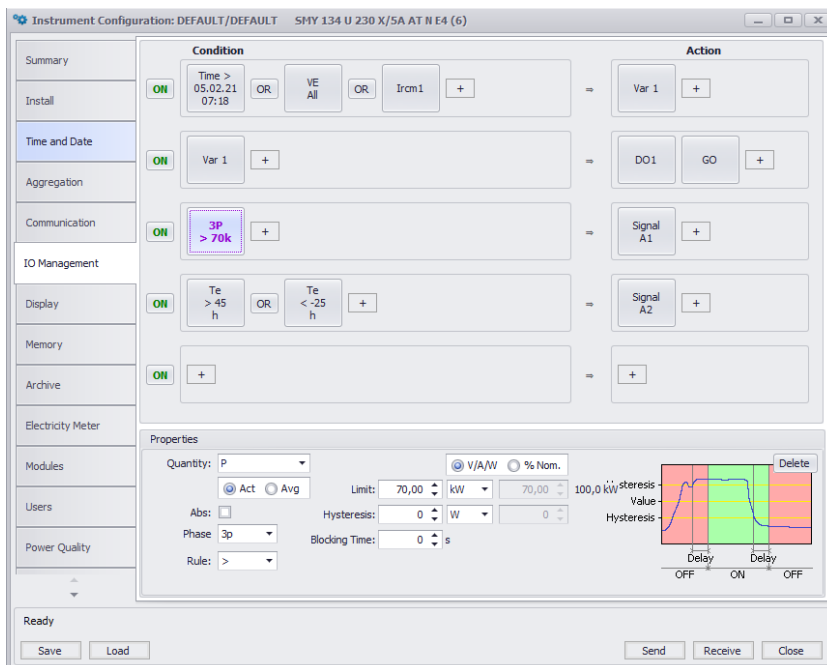

There are used three quantity conditions :

- one three-phase active power (**3P**) condition with limit of 70 kW in the 3rd clause
- two external temperature (**Te**) conditions with limits of 45 °C and -25 °C in the 4th clause

Fig. 6.33 : I/O Limits Screen

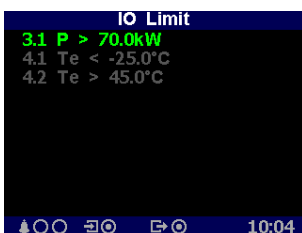

Now, when you add the *I/O Limits* user screen to the list of available screens and look it up, you can see all of the conditions including limits.

For clear identification, each of the conditions is marked with „X.Y“, where :

- X ... number of clause the condition is used in
- Y ... serial number of the condition in the clause

Fig. 6.34 : I/O Limit Change



If you need to change value of any limit displayed, select corresponding condition with buttons and and enter into editing mode with the .

Field with actual value of the limits appears. With the select digit (or sign) to change and set desired value with buttons and . In the same way set all of digits, step by step.

Finally, confirm the value with the and the limit value is stored.

6.2.2.3 Device State Condition

The condition can be configured to monitor various events mostly concerning the power quality (voltage events, power failures, rapid voltage changes etc.) or some instrument state changes.

Select desired event and – if applicable – check phases to be evaluated.

With the *Control* option you can set mode of event appearance evaluation :

- **1 ...** Level controlled mode. If any of events **appeared** (i.e. originated during present evaluation cycle or persisted from the previous one) result of the condition gets **true**; otherwise it gets **false**
- **0→1 ...** Edge controlled mode. If any of events **originated** during present evaluation cycle (i.e. not persisted), result of the condition gets **true**; if no of events originated (i.e. any did not appear at all or lasted only) it gets **false**

6.2.2.3.1 Device State Events

For easier orientation, events are arranged in groups, see overview in the next chapters.



Some of groups or individual events may not be available – it depends on instrument model and firmware modules installed.

6.2.2.3.1.1 Flags

At this group following events can be set :

- **Frequency ...** gets true if mains frequency is out of measuring range
- **Time Adjusted ...** gets true every time the instrument clock (RTC) is set or adjusted
- **10-minute tick ...** gets true periodically each 10 minutes
- **UIP Phase 1/2/3 ...** gets true if voltage or current of selected phase is out of measuring range (overflow, underflow)
- **Pst/Plt Phase 1/2/3 ...** gets true if value of selected flicker of selected phase exceeds preset limits (see *Power Quality* tab)

Fig. 6.35 : I/O Setup – Flags Device State Condition Properties

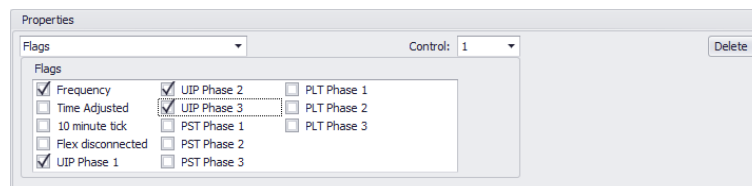

Result of the total event is logical sum of actual values of selected events.

6.2.2.3.1.2 Voltage and Power Quality Events

These events are evaluated if *Power Quality* firmware module is installed only. Following options can be selected :

- **Voltage Events – All**
- **Voltage Events – Swell**
- **Voltage Events – Dip**
- **Voltage Events – Voltage Interruption**
- **Power Quality Events – 100%**
- **Power Quality Events – 95%**
- **Rapid Voltage Changes (RVC)**



When Power Quality Events are used as control events for device state condition, note that they are evaluated regularly with period preset in the Power Quality group of parameters. Result of the evaluation is available at the end of each PQ evaluation cycle for one period of I/O block evaluation cycle only ! In the meantime, values of these events are false.

Fig. 6.36 : I/O Setup – Voltage Events Device State Condition Properties

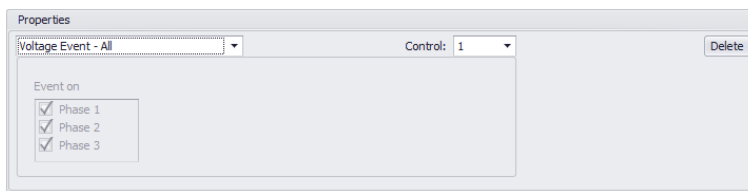

Selected event gets true if value/values of corresponding quantity/quantities exceeds limits preset in the *Power Quality* group of parameters – see below :

Fig. 6.37 : I/O Setup – Power Quality Parameters, Voltage Events Type Selection

Instrument Configuration: DEFAULT/DEFAULT SMY 134 U 230 X/5A AT N E4 (6)			
Aggregation	Property	Value (Low Limit[%])	Value (High Lim
	Record Interval	10 min	
Communication	▶ Frequency	94-104; 99-101	
	▶ Voltage	85-110; 90-110	
	▶ Unbalance	0-100; 0-2	
IO Management	▶ Flicker	0-1; 0-1	
	▶ RCS	0-9	
Display	▶ THDu	0-8	
	▶ Harmonics		
Memory	▼ Voltage Events	>110; <90; <5; h 2	
	Type	3P	
Archive	Reference	3P	
	Swell	3*1P	
Electricity Meter	Dip	90	
	Interruption	5	
Modules	Hysteresis	2	
	Imax	0 A	
Users	▶ Rapid Voltage Changes	Disabled; 5% Unom; h 1% Unom	
Power Quality			



Voltage events are evaluated either as three-phase events or three individual single-phase events according setting of Power Quality parameters – see the figure above.

If the Type parameter is set to **3P**, any event on any phase is considered as event of complete three-phase network – therefore you cannot select event evaluation in selected phases only.

If the Type is set to **3*1P**, events of individual phases are evaluated separately. Then you can choose event evaluation if some phases only. Result of the total event will be logical sum of values of events of selected phases.

6.2.2.3.1.3 Protection

Using this event in combination with a DO action simple voltage and/or frequency protection device can be created.

Fig. 6.38 : I/O Setup – Protection Device State Condition Properties

	%Unom	Delay [s]	Hz	Delay [s]	Hold Time [s]
U<	90	5	f<	48	10
U<	85	0,2	f<	47,5	0,2
U>	110	5	f>	50,5	1
U>	115	0,2	f>	51	0

Phase: L1 L2

You can set :

- **U<, U>, f<, f>**, ... voltage and frequency limits
- **Delay** ... minimum duration of the deviation to activate the condition
- **Hold Time** ... overlap of the condition activation after the deviation is over
- **Phase** ... phases to be evaluated

6.2.2.4 RCM Condition

Instruments equipped with a residual current monitoring (RCM) inputs can be used for indication of network isolation state failures using this condition.

Add the condition and check RCM currents $I_{\Delta x}$ to be monitored. Then set the residual current limit, polarity of deviation, actual/average current value evaluation, hysteresis of the deviation and delay to activation. The delay applies to the condition activation only; deactivation occurs immediately.

Fig. 6.39 : I/O Setup – RCM Condition Properties

RCM

1/4 IΔ 1

IΔ > 1 mA Act Avg

Hysteresis: 0,2 mA

Delay: 1 s

Up to four such different conditions can be created and used.



Do not forget to set residual current monitoring ratio **CT_{RCM}** in the Installation Setting group of parameters !

6.2.2.5 Time Condition

This condition can be used as a single timer.

- *Time* ... date & time since the condition result either gets true forever or starts pulsing
- *Fixed / Pulse* ... if *Fixed*, the condition gets true forever after the specified date & time passes; if *Pulse*, the condition gets true periodically (for one I/O block evaluation cycle) with the *Repeat every period*

Fig. 6.40 : I/O Setup – Time Condition Properties

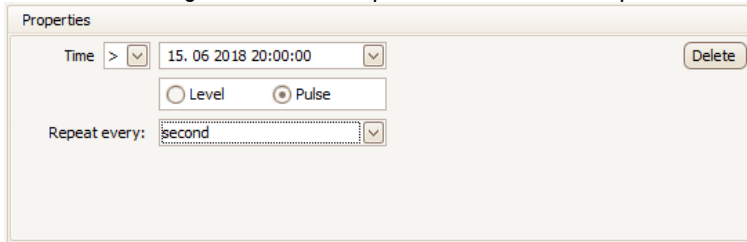

6.2.2.6 Variable Condition

If any *Variable* action is defined (see description above), it can be used in the same way as other basic conditions.

The setup is similar as the digital input condition – specify the variable number, polarity and the block time.

Fig. 6.41 : I/O Setup – Variable Condition Properties

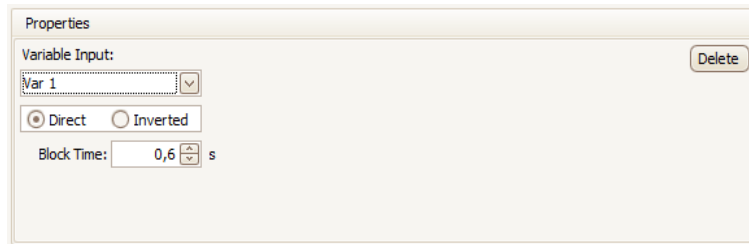

6.3 I/O Actual Data Presentation

6.3.1 Digital and Analog I/O

At the end of the actual data branch, the digital I/O actual state screen and, if set, the analog I/O state screen can be listed.

Fig. 6.50 : Digital I/O Actual Data Screen Example

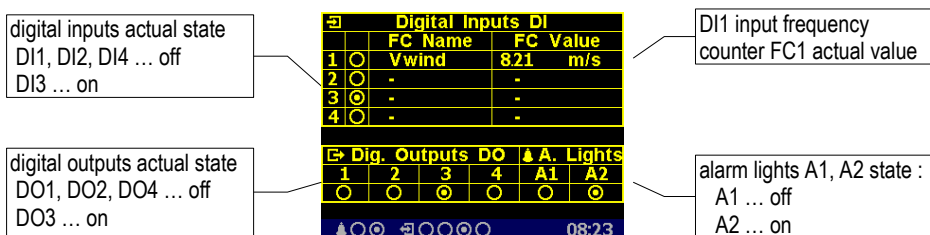

The digital I/O actual data screen shows actual state of all of the inputs and outputs :

- ... off-state (or inactive : the input voltage below defined threshold or open output)
- ... on-state (or active : the input voltage over defined threshold or closed output)

If a digital input frequency counter processing is set, its name (*Vwind* on the example) and actual value (*8.21 m/s*) is shown in appropriate line too. Otherwise, a dash is displayed only.

If any of analog quantities processing is set too, the analog I/O actual data screen is shown in the branch (otherwise, it is skipped) :

Fig. 6.51 : Analog I/O Actual Data Screen Example

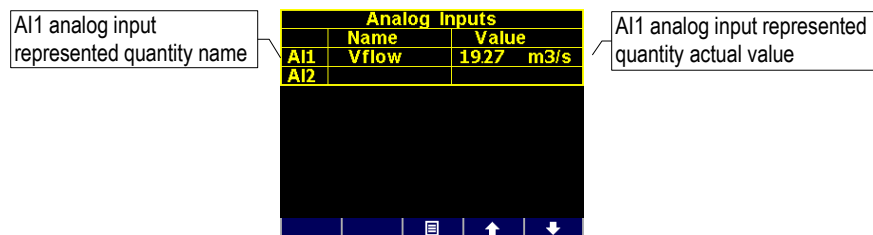

The analog input represented quantity value corresponds to actual input current or voltage at appropriate analog input according to the set ratio. At the example, the represented quantity *Vflow* has actual value of *19.27 m³/s*.

6.3.2 Pulse Counters

Fig. 6.52 : Pulse Counters Screen Example

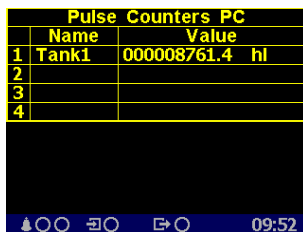

If at least one pulse counter action is used in the I/O setup the pulse counters screen can be listed in the electricity meter branch.

The table shows set pulse counters PC corresponding to digital inputs DI. Actual pulse counter value recalculated to preset pulse counter quantity units is displayed in appropriate line including its name and unit (shortened to 6/4 characters).

6.4 I/O Block Processing

The I/O block is processed periodically each measurement cycle (i.e. 200 ms @ 50 Hz), so it defines the fastest reaction time of all set actions.

The evaluation order is as follows :

1. **Conditions** of the clauses that are not switched-off are evaluated in the order in which they are listed – from top to bottom.

As default, individual conditions are evaluated from the left to the right. But expressions bound with the AND-operator are always evaluated first, then that bound with the OR - operator.

If any variable used in a condition, values from the previous I/O block evaluation cycle are used. In the first evaluation cycle (after the instrument power-up or a restart), value of all the variables is false, excluding that keeping true due to the *Persistent* option.

2. **Variable type actions** (of clauses that are not switched off) are evaluated from top to bottom (the variables get new values).
3. The steps 1 and 2 executed once more with the new variable values (the conditions and variable values are updated).
4. All of the **actions** (of the clauses that are not switched off), excluding the variable type actions, are evaluated and executed from top to bottom, using updated conditions.
5. Updated values of the **variables** are stored for the next I/O block evaluation step.

6.4.1 Digital Inputs

6.4.1.1 Digital Input Filter

Digital inputs are read with period of 0.2 ms. For interference suppression, the signal is filtered digitally (by firmware). Default limit frequency of the filter is preset to 100 Hz.

The filter limit frequency can be set in *Advanced* parameters. *The DI filter minimum pulse width* parameter defines minimum pulse/gap width in milliseconds. When, for example, limit frequency of 100 Hz is desired set the parameter to 50 ms (pulse 50ms + gap 50 ms = 100ms). Pulses and gaps shorter than the set limit will be filtered.



It is not recommended to increase the limit frequency too much. Otherwise interference spikes can cause false measurement.

On contrary, when maximum output frequency of a sensor connected to the instrument is lower than 100Hz, it is suitable to decrease the limit frequency to corresponding value.

6.4.1.2 Digital Input as Frequency Counter

6.4.1.2.1 “Frequency” Mode

The frequency counter operation is based on measurement of duration between last two pulses. After the instrument startup, the quantity value is set to zero until at least two pulses come. Then the counter value is evaluated periodically each measurement cycle (cca 0,2 s).

6.4.1.2.2 “PWM” Mode

The quantity value is controlled by duty cycle of incoming signal. Evaluation runs as follows :

- after the instrument startup, the quantity value is undefined for 50 measurement cycles (cca 10 s)
- then the value is evaluated periodically each measurement cycle (cca 0,2 s)
- if the duty cycle drops below 0,5%, it is rounded to 0%; if it exceeds 99,5% it is rounded to 100%

6.4.1.3 Digital Input as Pulse Counter

The pulse counters have capacity of $2^{32} - 1$ pulses. Then overflow occurs and the counter starts to count from zero again. Contents of the counters is maintained in case of power failure.

Actual state of the counters can be checked via a communication link only using the ENVIS-Daq program.

6.4.2 Digital Outputs

Digital outputs are processed and refreshed after each measurement cycle, i.e. usually every 200 ms.

The only exclusion are the outputs set to *pulse function*.

6.4.2.1 Pulse Outputs

After the pulse function mode is set, every 200 milliseconds the instrument executes evaluation of the measured electric energy. If the increment of recorded electric power is higher or equal to the quantity of power per one pulse, the instrument will transmit one or two pulses. The mentioned description shows that the fluency of pulse transmission is +/- 200 ms.

The pulse width and minimum pulse gap are 50 / 50 ms (compliant with so-called S0-output definition), maximum frequency is 10 pulses per second.

7. Local Bus

The local bus is a proprietary bus combining signals for communication, synchronization and powering of external modules. Using the local bus interface, basic electrical parameters of up to additional 20 three-phase branches (= feeders), i.e. 60 currents can be measured with up to five EMI 12 modules.

SMY/SMP instrument automatically detects modules connected and performs their subsequent configuration. Actual values of measured quantities are available immediately after connection and user configurations of newly detected modules can be done. To uniquely identify the modules in the settings, their serial numbers are used (can be found on the instrument label).

Traffic on the local bus is controlled by a *master* – in our case it is a SMY/SMP instrument. EMI 12 modules reply to the master’s requests - they operate as *slaves*.

7.1 Connection

Power supply option „S“ SMY/SMP instrument models (i.e. with auxiliary power supply in range 12 – 24 V DC) are used for such applications.

Fig. 7.1 : Multiple Feeders Measurement via Local Bus

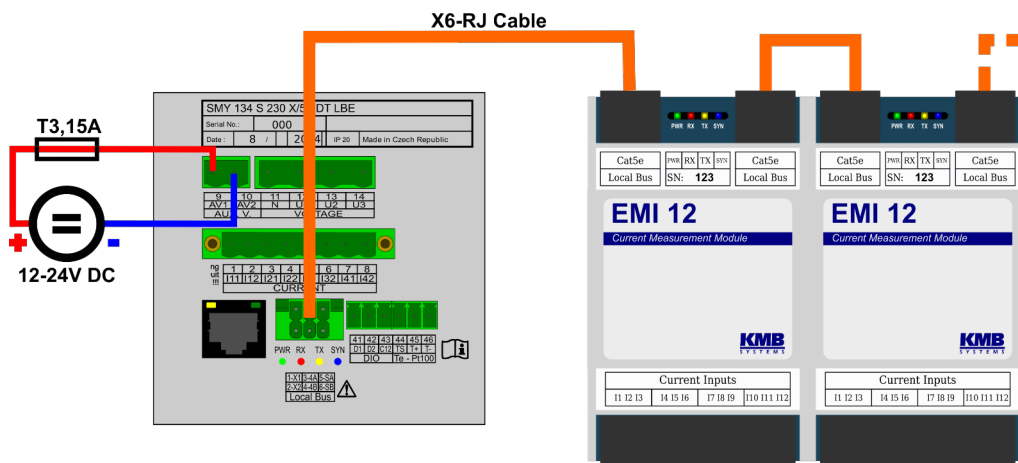

Instrument power supply terminals **AV1 / AV2** are internally connected to the local bus interface terminals **X1 / X2.**, respectively. Therefore auxiliary power voltage for the EMI units is provided automatically after the instrument is powered.



External fuse of maximum rating of T3.15A (T=slow character) must be installed between 12-24 VDC power supply output and the instrument power supply input. Optionally, if the 12-24 VDC power supply allows to set the current limit of the output to approx. 3A, the fuse can be eliminated.

Otherwise the instrument can be damaged in case of accidental short circuit on the local bus !

For interconnection with the EMI modules the instruments are equipped with 6-pin „DFMC“ connector - see central connector in the bottom row on the picture below.

Fig. 7.4 : RJ-RJ Cable for Local Bus

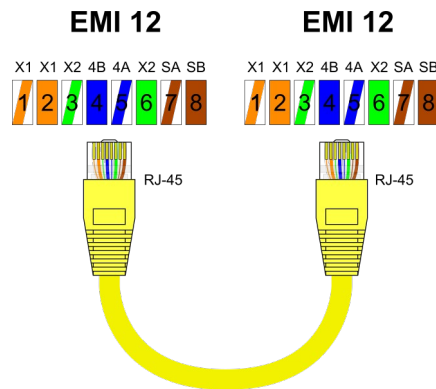

Maximum length of the local bus (i.e. distance between master and the last EMI 12 module installed) should not exceed 15 m. Otherwise reliability of operation can be degraded.

Cables of usual lengths can be delivered together with the instruments – ask your dealer.

Proper connection of EMI 12 modules with master can be checked with their LED indicators – the PWR indicators must light and all of others must flash.

7.2 LED Indicators of Local Bus

PWR – green ... lights when supply voltage is present on the bus

SYN – blue ... flashes synchronously with the synchronization pulse every ten periods of the network frequency (or twelve periods at 60Hz networks)

TX – yellow ... flashes when sending data to the bus

RX – red ... flashes when receiving data from the bus

7.3 Commissioning

Connect SMY/SMP instrument to a computer via any of communication interfaces. Run the ENVIS.Daq application, select the interface chosen and connect to the instrument – a window similar to the following example should appear :

Fig. 7.5: ENVIS-Daq - Connected Instrument Main Window

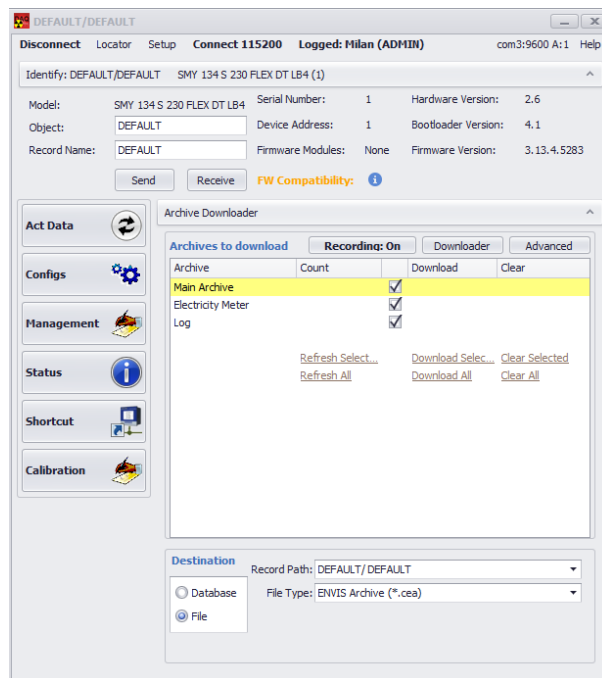

Press the *Configs* button. A new window with sub-settings tabs appears. Select the *Local Bus* tab :

Fig. 7.6: ENVIS-Daq - Local Bus Config, Nothing Configured

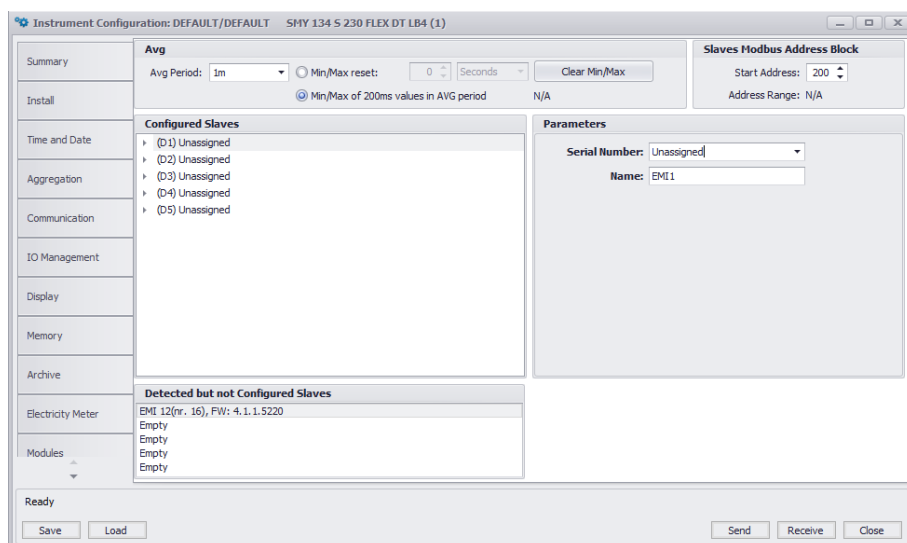

If any slaves properly connected to the local bus, they should appear in the *Detected but not Configured Slaves* block – in our case there is EMI 12 module of serial number 16.

If no slave detected (*Empty* in all of five rows), recheck the local bus indicators both on master and all of slaves; if they are OK, press the *Receive* button – then status of the local bus refreshes.

As soon as any slaves detected, it is necessary to configure them. Select the first slave in the *Configure Slaves* block, i. e. the slave marked as *D1* and then in the *Parameters* block select serial number of the first unconfigured slave – no. 16 :

Fig. 7.7: ENVIS-Daq - Local Bus Config, Configuring of a Slave, Step 1

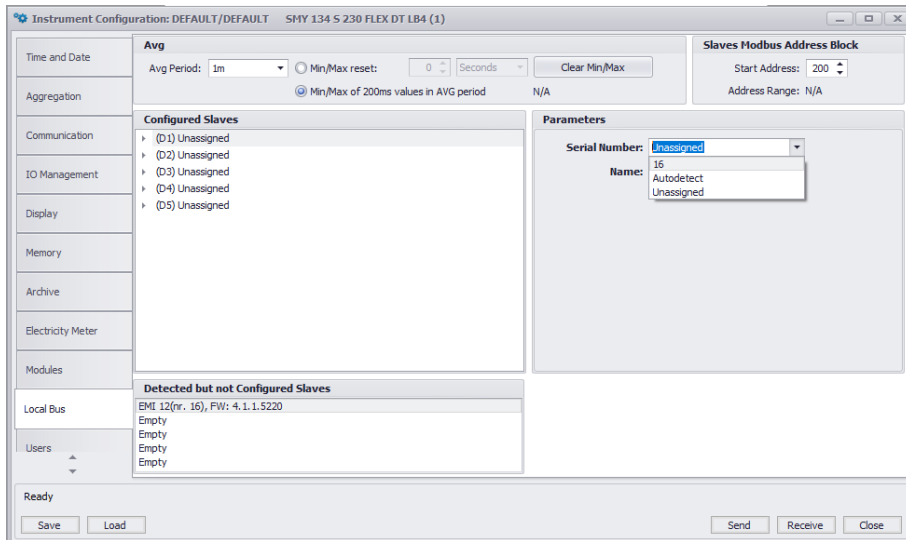

After the selection, the slave of serial no. 16 appears in the *Configured Slaves* block as slave D1 :

Fig. 7.8: ENVIS-Daq - Local Bus Config, Configuring of a Slave, Step 2

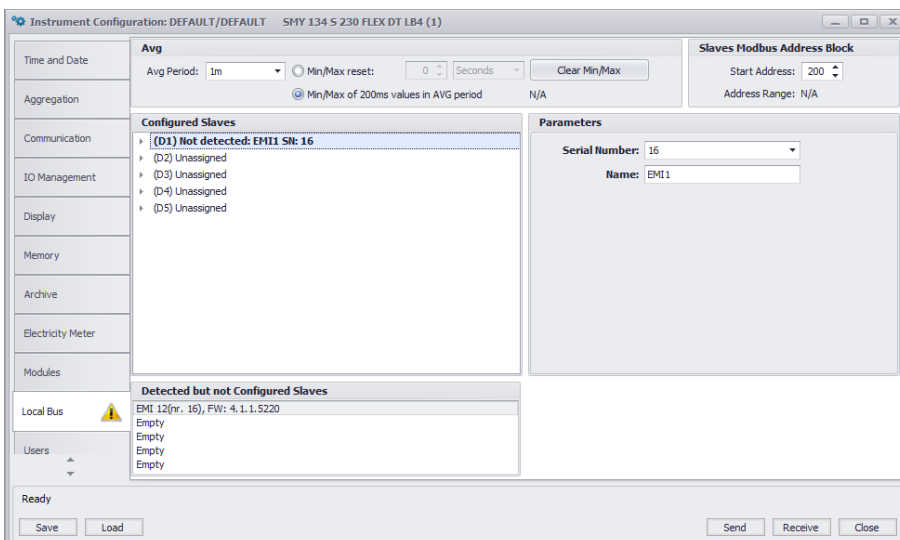

Now it is necessary to send this setup into the master – press *Send* and then *Receive*. The master process the setup and returns new state :

Fig. 7.9: ENVIS-Daq - Local Bus Config, Configuring of a Slave, Step 3

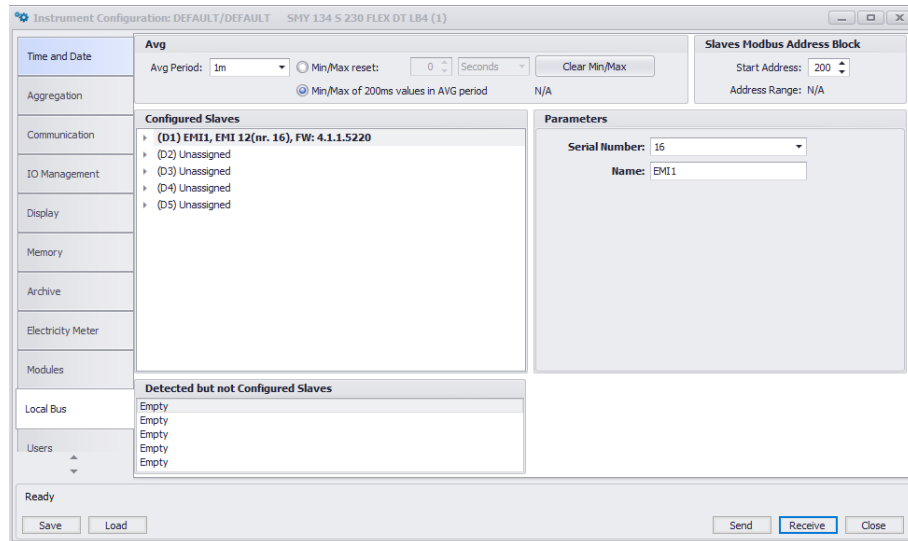

Note that slave D1 in the *Configured Slaves* block contains more detailed information now. Simultaneously, the slave disappeared from the *Detected but not Configured Slaves* block.

As default, name EMI1 is assigned to it. For easier orientation in measured data you can rename the slave freely in the *Parameters* block as follows :

Fig. 7.10: ENVIS-Daq - Local Bus Config, Configuring of a Slave, Step 4

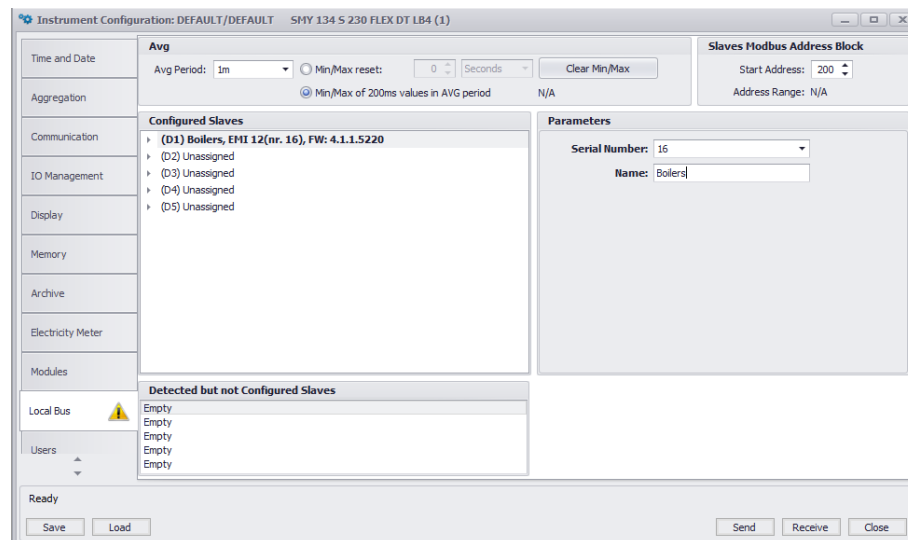

Now the slave is renamed to *Boilers*. Besides the name following information is displayed at each of configured slaves :

- slave type and serial number (EMI 12(nr.16))
- firmware no. of the slave (FW:4.1.1.5220)

Next, it is necessary to set individual feeders of the slave. Click on the triangle in the front of the slave D1 and select feeder F1 :

Fig. 7.11: ENVIS-Daq - Local Bus Config, Configuring of a Slave, Step 5

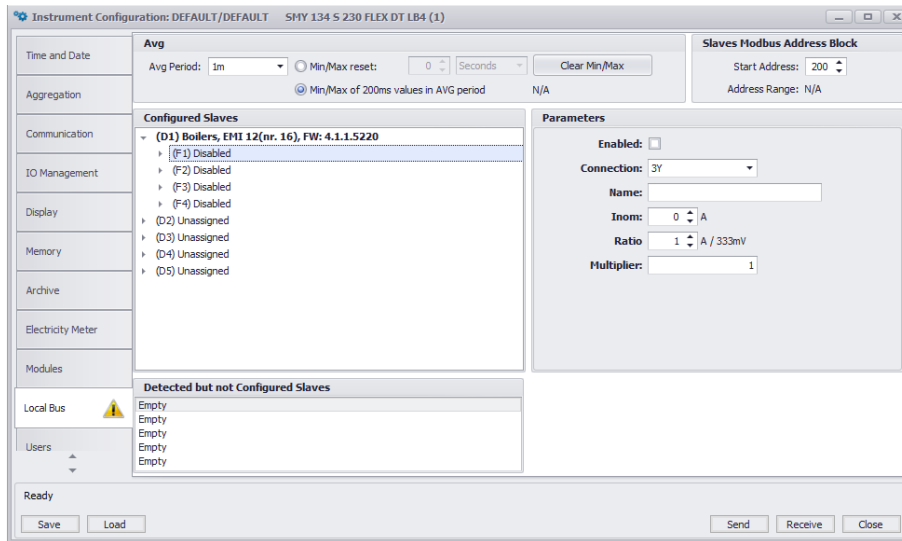

As you can see, all of feeders are disabled as default and no measurement is in progress. In order to start measuring, each of the feeders must be enabled first in the *Parameters* block – check appropriate checkbox.

Then set other parameters of the feeder (see overview of parameters below) according following example :

Fig. 7.12: ENVIS-Daq - Local Bus Config, Configuring of a Slave, Step 6

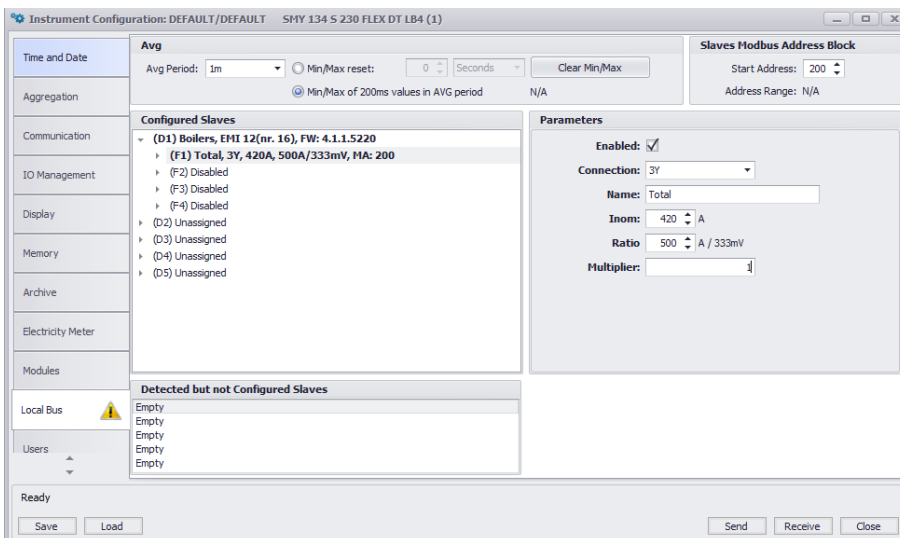

At three-phase networks (connection types 3Y, 3D or 3A) phase currents of each feeder must be connected to EMI 12 modules with right polarity and right order (L1 - L2 – L3), i.e. corresponding to order of phase voltages of the master (SMY/SMP instrument). Otherwise powers and power factors evaluated will be wrong !



Generally, to keep order in installation it is primarily recommended to reconnect the current inputs if they not match voltage order. Only when it is difficult or impossible, you can solve such problem with so called „channel setup“ – see detailed description below.



At the shown example there is selected the most common connection type 3Y. If you need to set other type, see detailed setup description in the parameters overview below.

In the same way you can set other feeders of the slave. Then send the setting into the master with the *Send* button and read it back with the *Receive*. Situation can look like this :

Fig. 7.13: ENVIS-Daq - Local Bus Config, Configuring of a Slave, Step 7

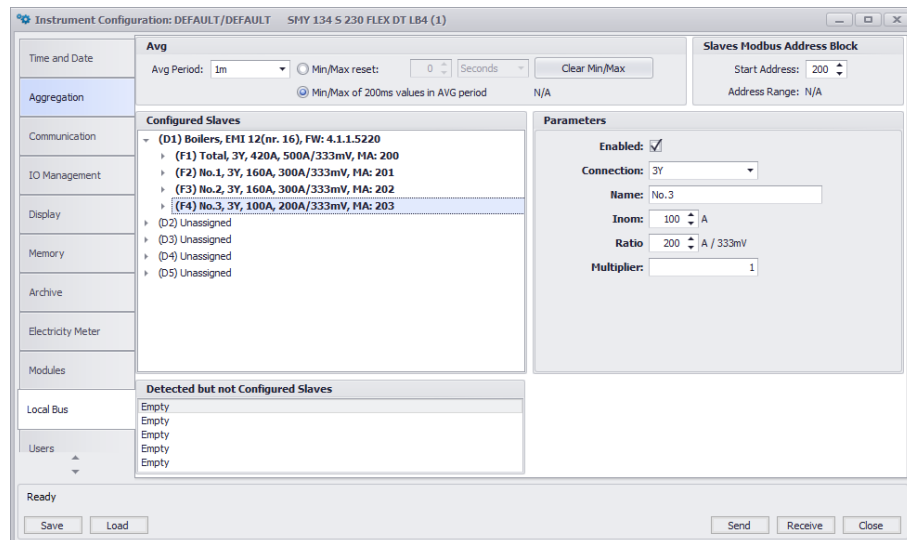

Similarly you can set other slaves, if any detected.

7.3.1 Local Bus Parameters Overview

The *Local bus* tab window consists of five blocks :

7.3.1.1 “Averaging” Block

- **AVG Period** ... averaging depth
- **Reset Min/Max** ... resetting method of minima and maxima registered

7.3.1.2 “Slaves Modbus Address Block” Block

- **Start Address** ... If data from the EMI modules to be read by a third party device/PC, any suitable interface of the master (= SMY/SMP instrument in our case) supporting the Modbus protocol can be used. With the *Start Address* you can define the Modbus address of the 1st feeder (branch) data block of the 1st configured EMI 12 module (= slave). Data blocks of the next feeders can be read from consecutive addresses.

For example, the 1st feeder data block of 1st EMI 12 module can start at address 200, the next feeders of the same module at 201, 202 and 203; the 1st feeder of the 2nd module at address 204, etc.

If data of EMI 12 modules are presented on the master instrument display and/or in the ENVIS application only, value of this parameter is irrelevant

7.3.1.3 Configured Slaves Block

Contains tree structure of already set (=configured) modules.

At the highest level, there are 5 positions for up to 5 EMI 12 slaves, marked as D1 to D5. After the first installation the modules are not configured yet – therefore specification of the positions is *Unassigned*.

As soon as any of *detected slaves* is converted to *configured slave* by selection of its serial number in the *Parameters* block, it appears in the *Configured Slaves* block. Now you can set its *Name* and it

appears in the block too. Then send the setup with new name into the master with the *Send* button and read the setup back with the *Receive*. Next information appears behind the slave name:

- slave type (model)
- serial number
- firmware version

Under each slave there are 4 positions for three-phase feeders (branches), marked as F1 to F4 (click on the preceding triangle to show them). Until enabled, they are marked *Disabled* and the slave does not measure them.

After selection of a feeder you can set :

- **Enable** (or Disable) the feeder ... Enables/disables the selected feeder or channel. If a feeder (or a channel) disabled no measurement is performed. Disable when the feeder (branch) or channel is not used.
- **Name** ... Sets the slave, feeder (branch) or channel name. It serves mainly for easier orientation in measured data.
- **Connection Type** ... Selects connection type of selected feeder (branch). Three-phase connection types are available: star (**3Y**), triangle (**3D**) and Aron (**3A**).

It is also possible to use the **3*1Y** mode, which allows the measurement of three independent single-phase currents.

The feeder F4 can be used for measurement of neutral currents of feeders 1 to 3 too. In such case select the **3*In** mode.

- **Inom** ... Nominal current of selected feeder (**3Y**, **3D**, **3A** or **3*In**) or channel (**3*1Y**).
- **CT Ratio** ... Conversion ratio of current transformers of selected feeder or channel.
- **Current Multiplier** ... Current multiplier of selected feeder or channel (to correct measured value in case of multiple turns through the CT, for example). Default value is 1.

These parameters including modbus address (MA) of corresponding data block (see setup in the *Slaves Modbus Address Block*) appear in appropriate feeder row in the *Configured Slaves* block.

According connection type selected you can use other options of the feeder. Click on the triangle preceding the feeder and three „channels” marked CH1 to CH3 appear. :

Fig. 7.14: ENVIS-Daq - Local Bus Config, Feeder Channel Option

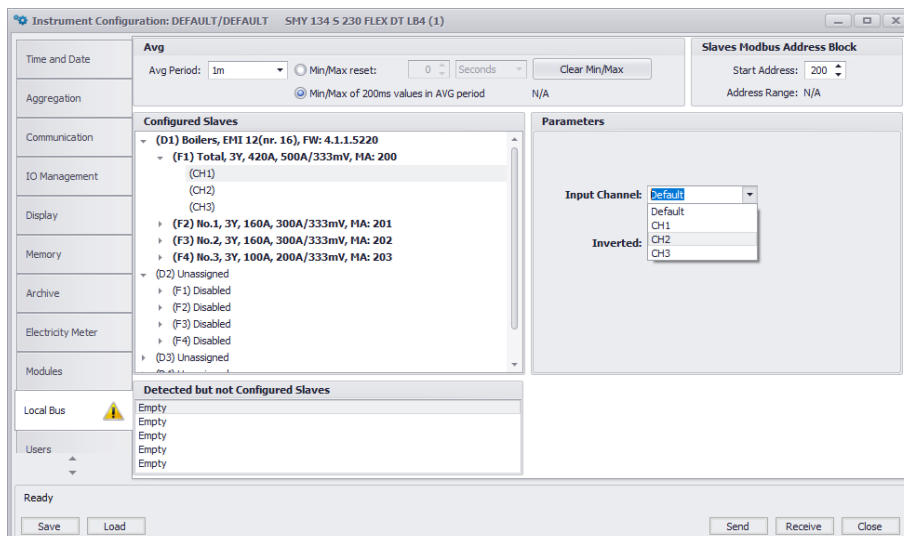

The channels correspond to currents of the feeder. After selection of any of current channel you can :

- change phase order of the currents. For example, if current inputs of phase L1 and L2 connected wrong by accident to the EMI 12 module, you can toggle them to right position by the setup shown below without physical reconnection
- similarly, if current input L3 connected with opposite polarity it can be simply corrected by checking the *Inverted* checkbox - see below

Fig. 7.15: ENVIS-Daq - Local Bus Config, Feeder Channel Change

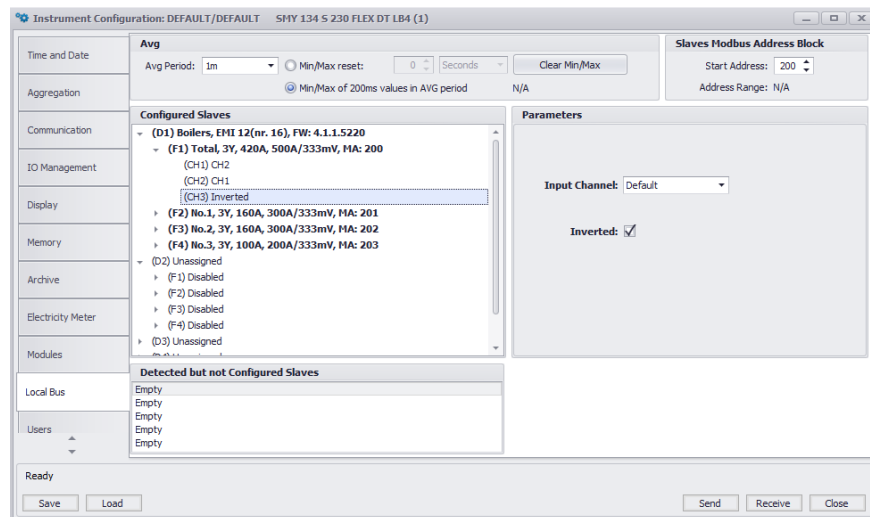

When general (single-phase) currents connected to a feeder input connection type of the feeder must be set to 3^*1Y . Then the feeder setup is rather different :

- the feeder name does not exist, but now you can set *Name* of individual channels (currents) – *Light1*, *Light2* and *Wallsocket* in the example below
- for each channel (=current) so called *Assigned Voltage* (of master) must be set . It determines reference voltage channel of the master that is used for power and power factor evaluation of the channel. If, for example, the currents of channels CH1 (*Light1*) and CH2 (*Light2*) are powered from voltage L1, their assigned voltages must be set accordingly; similarly, assigned voltage of channel CH3 (*Wallsocket*) is set to L2, because the channel is powered from this voltage.

Fig. 7.16: ENVIS-Daq - Local Bus Config, Single Phase Channels

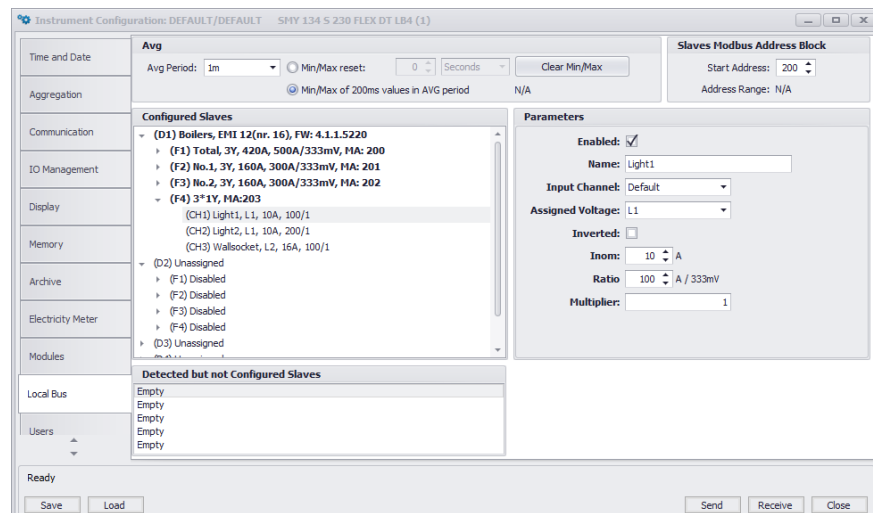

7.3.1.4 Detected but not Configured Slaves Block

Contains list of detected modules that are not yet prepared for usage (*not configured*).

Each slave occupies one row and reports its type, serial number and firmware version.

If less than maximum of 5 slaves detected, residual rows reports *Empty*.

7.3.2 Autodetect Option

The *Autodetect* option can simplify configuration of slaves. It allows to arrange configured slaves in desired order automatically.

Master continually monitors the local bus and as soon as it detects any new slave, it usually posts it in the *Detected but not Configured Slaves* block list only and waits for next commands.

But when any position of the *Configured Slaves* list is set into the *Autodetect* mode, as soon as a new slave is detected on the local bus, it is immediately automatically paired with the first position just being in the *Autodetect* mode. The slave occupies this position and becomes *configured* one. Simultaneously, *Autodetect* mode of the position is cancelled.

The procedure works as follows :

1. Disconnect all of slaves from master by disconnecting local bus cable. Read new state from master by pushing of the *Receive* button – then message *Empty* in the *Detected but not Configured Slaves* block appears in all of five rows (no detected slave at the moment).
2. Select positions D1 to D5 in the *Configured Slaves* block, step by step, and set them to *Autodetect* mode (see below). Then send the setup into the master (*Send*) and read actual state back (*Receive*). Situation should look like this :

Fig. 7.17: ENVIS-Daq - Local Bus Config, Autodetect Mode, Step 1

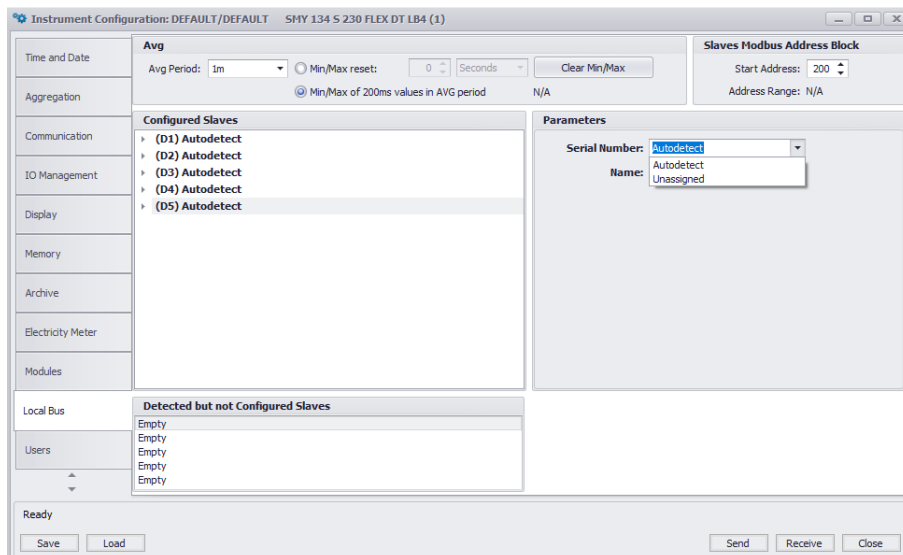

3. Now connect the slave you want to occupy the D1 position in the list to the local bus and check the local bus LED indicators on the slave.
4. Read new state of the master with the *Receive* button.

Fig. 7.18: ENVIS-Daq - Local Bus Config, Autodetect Mode, Step 2

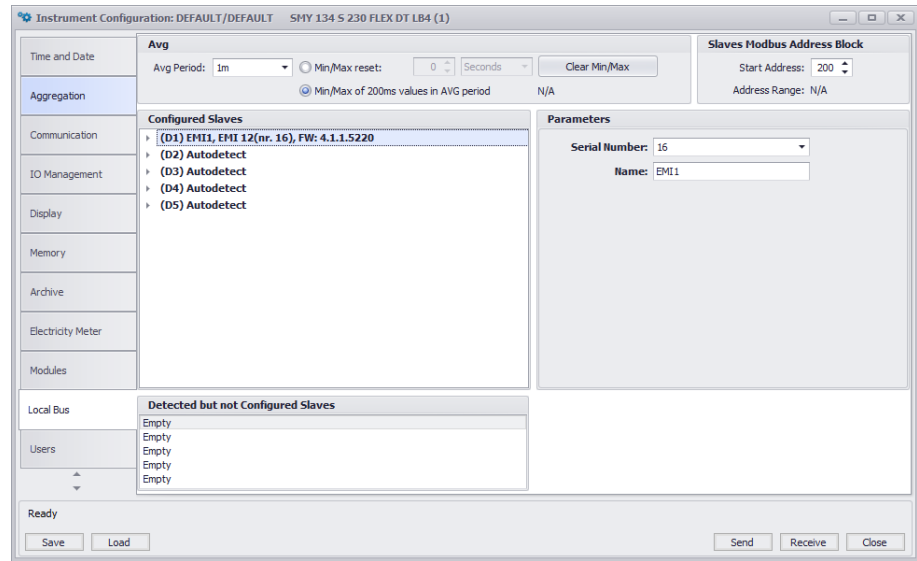

In the *Configured Slaves* block you can see the slave newly added.

5. Repeat steps 3 and 4 until all of slaves added.



Reading new state of the master after connecting of each slave as prescribed in the step no. 3 is not necessary. You can simply connect the slaves one after another and then check final state of the master with the Receive button only in the end.

After all of slaves added to the *Configured Slaves* list, set all of necessary parameters of all of slaves and send the setup into the master with the *Send* button.

7.4 Measured Data Presentation

7.4.1 ENVIS-DAQ Application

In the actual data window, click on the *EMI Act* tab. On the panel you can check actual data of individual EMI 12 modules. Feeders are arranged from top to bottom in order of the *configured slaves* list.

Fig. 7.19: ENVIS-Daq - Actual Data of Local Bus Module

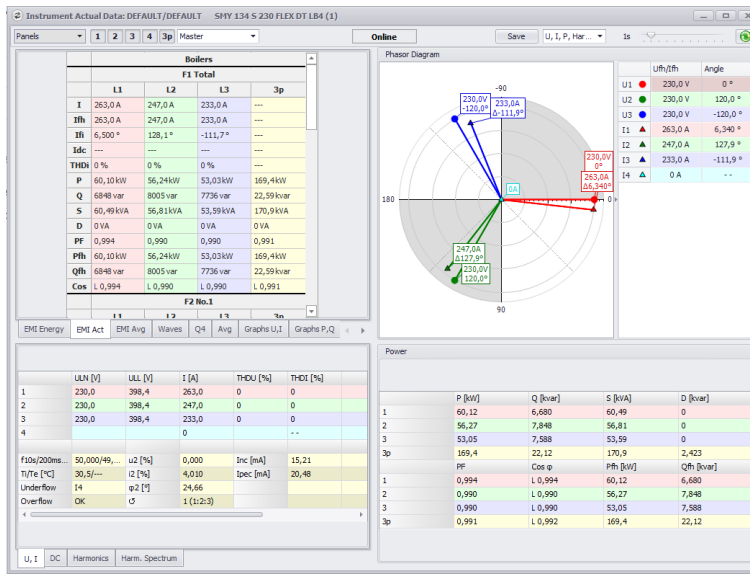

If more modules installed, their data are arranged in the next columns right from the previous module. In the same way you can check average values of the quantities under the *EMI Avg* tab. In addition to the average values, you can also check their registered maxima and minima - the selection is made with the switch in the upper left corner of the tab.

Finally, under the *EMI Energy* tab there are corresponding energies registered.

Fig. 7.20: ENVIS-Daq - Energies of Local Bus Module



The energy counters are processed and backed up in the EMI 12 modules. Counters of each feeder can be individually cleared with the *Clear* option below each feeder data.



For easy check of the EMI 12 modules measurement function already during installation, not only data columns of configured modules but that of detected modules too are displayed.



7.4.2 Instrument Display

Instruments SMY/SMP equipped with the local bus interface, has special icon in the main menu. Here you can check actual, average and energy data of modules connected to the local bus.



Any of the screens described below can added between user screens - see the Main Data Group chapter above.



7.4.2.1 Local Bus Actual & Average Data



Actual / Average values of quantities measured by modules connected to the local bus in numeric form are arranged in the groups.

Below there are shown screens of actual data :

Fig. 7.21: Local Bus Module Actual Data on Display

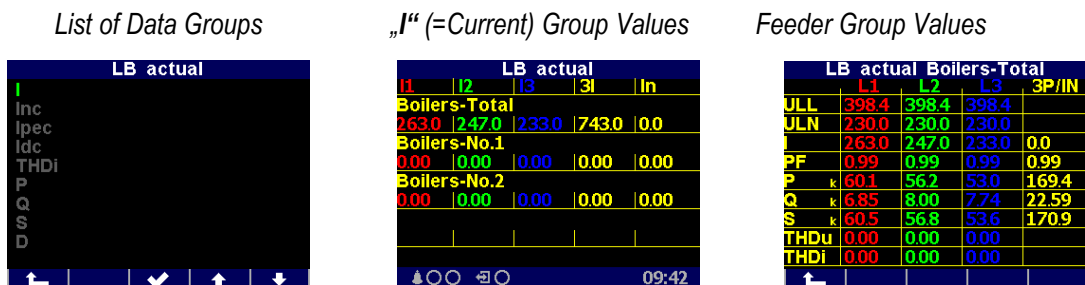

At the first screen there is list of quantities' data groups. It consists of two parts :

- data grouped by quantities ... I, INC, IPEC, IDC, THDi, P, Q, S, D and PF. Each of group contains values of selected quantity of all of modules connected to the local bus
- data grouped by feeders (branches) ... these groups are marked with feeder (branch) names (*Boilers-Total* in our example) and each one contains summary of values of all of quantities of selected feeder

In the same way you can navigate through average data screens. They contains average values of the local bus modules aggregated in the same way as average values of master instrument itself.



7.4.2.2 Local Bus Energy Data

Each of module connected to a local bus evaluates energy counters too. Their actual values are arranged in the same way as that of actual and average values described above.

Fig. 7.22: Local Bus Module Energy Data on Display

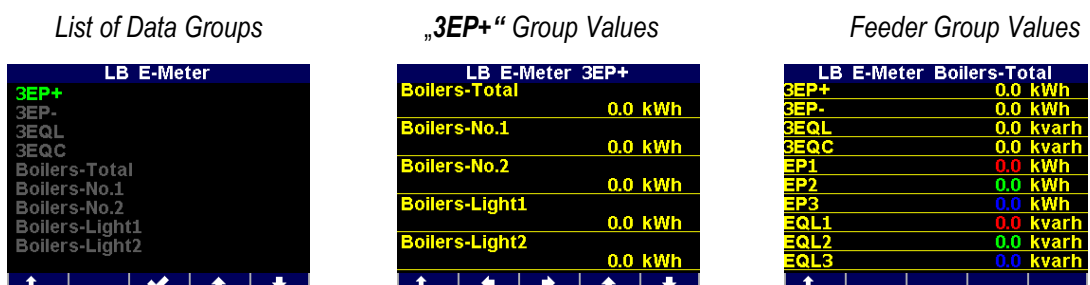



To clear individual feeder energy counters use ENVIS-DAQ application .

8. Computer Controlled Operation

Monitoring the currently measured values and the instrument setup can be done not only on the instrument panel but also using a local or remote computer connected to the instrument via a communication link. Such an operation is more comfortable, and it also allows you to use all the options of the instrument, such as adjusting the inputs/outputs or setup and the monitoring of courses recorded into the internal memory of the instrument, which it is not possible from the panel of the instrument.

Following chapters describe instrument communication links from the software point of view and embedded webserver only. The detailed description of ENVIS program can be found in the program manual.

8.1 Communication Links

8.1.1 Local Communication Link

Instruments can be equipped with a serial interface USB 2.0, on the front panel. Using this interface, adjusting the parameters of the instrument and the transmission of data into a portable computer can be accomplished. It requires to interconnect the instrument with the PC using the appropriate communication cable (connector type "Mini-B", see optional accessory list).

Considering the fact that the instruments can be also equipped with a remote communication link, the described communication link is called *Local*.

8.1.2 Remote Communication Links

The instruments may be optionally equipped with the remote communication link for operation of the instrument via a remote computer. Subsequently, this computer can execute a remote adjusting of the instrument and transmission of current or recorded data.

The type of interface can be either RS-485 or Ethernet. Appropriate connector is situated at the rear panel. It is supposed the cable for remote communication link to be provided by customer.

One or more instruments can be connected to the remote PC via this link. Each instrument must have an adjusted proper remote communication address and protocol. These specifications can be set manually or by the computer via a local communication link in ENVIS program.

The remote communication link is always isolated from the internal circuits of the instrument.

Selected models can be equipped with the second communication link RS-485.

8.1.2.1 RS-485 Interface (COM)

Up to 32 instruments at a maximum distance of 1,200 metres can be connected to this interface. Used signals : **A+** , **B-** , **G** , and optionally **A+2** , **B-2** , **G2**.

Each instrument must have a different communication address within the range of 1 to 253 preset during the installation.

A USB/485 level converter must be installed on the computer side. For suitable converters see optional accessory list.

In case of two communication links they are isolated both from the instrument internal circuitry and mutually too, terminals No. 30 and 33 *are not connected internally !*

Tab. 6.1 : RS-485 Remote Communication Links Wiring

signal	COM1 interface		COM2 interface
	terminal No.		
	“RR / RI / II” models	“V / DT / W / AA / AT” models	“V / DT / W / AA / AT” only
A+ (A+2)	28	31	28
B- (B-2)	29	32	29
G (G2)	30	33	30

8.1.2.1.1 Communication Cable

For common applications (cable length up to 100 metres, communication rate up to 9,600 Bd) the selection of the right cable is not crucial. It is practically possible to use any shielded cable with two pairs of wires and to connect the shielding with the Protective Earth wire in a single point.

With cable lengths over 100 metres or with communication rates over 20 kilobits per second, it is convenient to use a special shielded communication cable with twisted pairs and a defined wave impedance (usually about 100 Ohm). Use one pair for the **A+** and **B-** signals and the second pair for the **G** signal.

Recommended wire type: shielded double twisted pair 2 x 2 x 0.2 mm², for example Belden 9842 or Unitronic Li2YCY (Lappkabel)

Recommended minimum conductor cross-section : 0.2 mm²

Maximum conductor cross-section : 2.5 mm²

8.1.2.1.2 Terminating Resistors

The RS-485 interface requires impedance termination of the final nodes by installation of terminating resistors, especially at high communication rates and long distances. Terminating resistors are only installed on the final points of the link (for example one on the PC and another on the remotest instrument). They are connected between terminals **A+** and **B-**. Typical value of the terminating resistor is 120 Ohm.

8.1.2.2 Ethernet (IEEE802.3) Interface

Using this interface the instruments can be connected directly to the local computer network (LAN). Instruments with this interface are equipped with a corresponding connector RJ- 45 with eight signals (in accordance with ISO 8877), a physical layer corresponds to 100 BASE-T.

Type and maximum length of the required cable must respond to IEEE 802.3.

Each instrument must have a different IP- address, preset during the installation. The address can be set from the instrument panel or you can use the ENVIS-DAQ program. For detection of actual IP- address you can use *the Locator* function.

Furthermore, you can set the DHCP function for dynamic IP-address allocation.

8.2 Communication Protocols

The remote communication link parameters must be set according chapter *Remote Communication Setting* - see above.

8.2.1 KMB Communications Protocol

This manufacturer proprietary protocol is used for communication with ENVIS program.

8.2.2 Modbus-RTU Communications Protocol

For the chance of easier integration of the instrument to the user's program, the instrument is also equipped with the Modbus - RTU communications protocol. A detailed description of the communications records can be found in an appropriate manual.

8.2.3 M-Bus Communications Protocol

Standard setup for this interface is address 1, communication rate 2400 Bd and 9 bits with even parity protocol. Secondary address is BCD-coded instrument serial number.

Maximum communication rate is 9600 Bd. Description of the protocol can be found in *the Description of Communication Protocol* manual available on www.kmbystems.eu.

8.3 Embedded Webserver

All of instruments with Ethernet remote communication interface are equipped with an embedded webserver, thus both all of main measured values and the instrument setting can be viewed with a standard web browser. It requires to set properly the instrument remote communication parameters and to connect it to the network. Then in the web browser enter appropriate IP-address of the instrument and information from the instrument appears as shown on the figure.

Fig. 7.1 : Webserver



9. Firmware Extension Modules

Standard firmware contains specific modules with additional functionality. To enable the modules they must be activated first. For activation code contact the supplier of your instrument or enquiry directly our sales department.

9.1 Power Quality Module

Instruments with PQ module enabled do measure the power quality indices as required by EN 50160. It enables specific features in the power analyser required for the PQ monitoring: Flicker indices, interharmonics and voltage events as defined in EN 50160, IEC EN 61000-4-30, -4-7 and -4-15. This module also activates secondary archive - the PQ Main Archive, which contains aggregated value readings in the required interval. Module also adds an archive of voltage events - the PQ Event Archive - which contains start-/end- time and extremal values of every recorded voltage fluctuation.

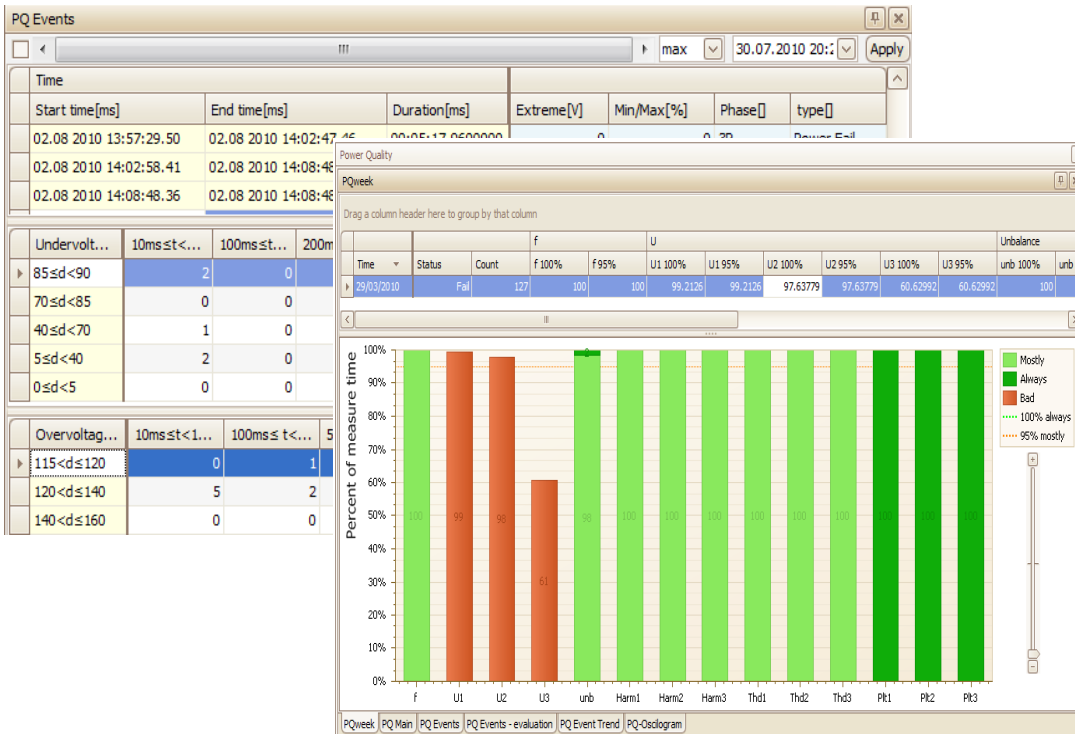

9.2 Ripple Control Signal Module

The RCS module (Ripple Control Signal or mains signalling voltage) activates an ability to detect, evaluate, decode and store various ripple control signals on the monitored power network. Signalling frequency and telegram threshold voltage can be specified. Signals get decoded and archived in the internal memory. On instruments with display the signal level can be also displayed live.

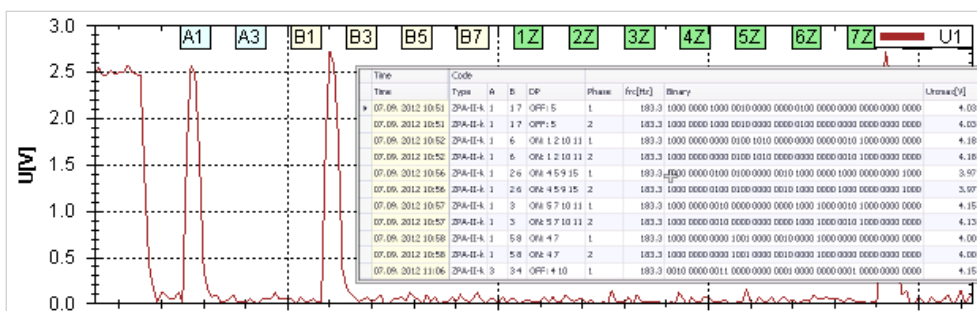

9.3 General Oscillogram Module

This module extends the ability to record detailed oscillographic events into internal memory. For details, see the *General Oscillogram Firmware Module* application note.

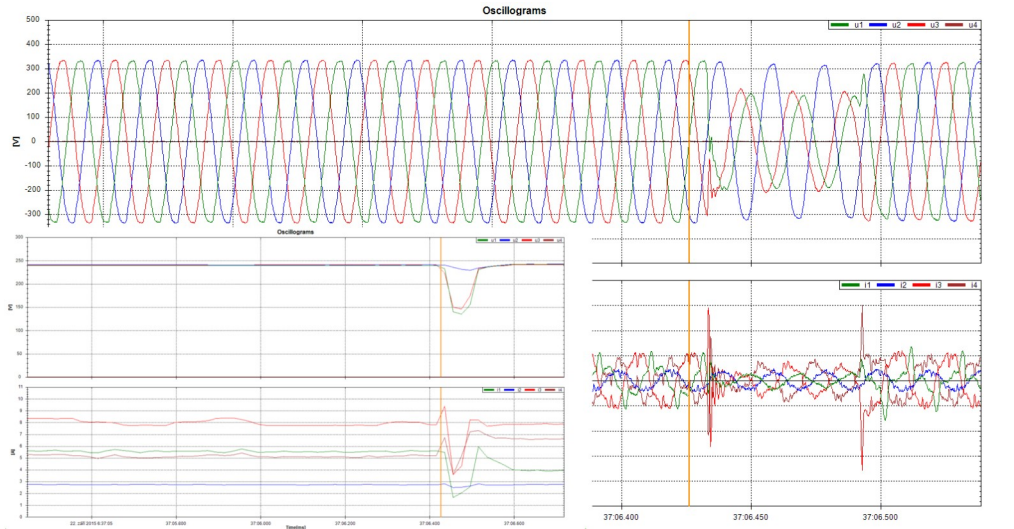

9.4 Modbus Master Module

This firmware extension adds capability to read out and record Modbus registers from slave units into the memory. Simply it allows to store locally data from simpler memory less devices connected on the slave RS 485 bus. This module allows creation of complex monitoring and control systems by using small and relatively simple building blocks.

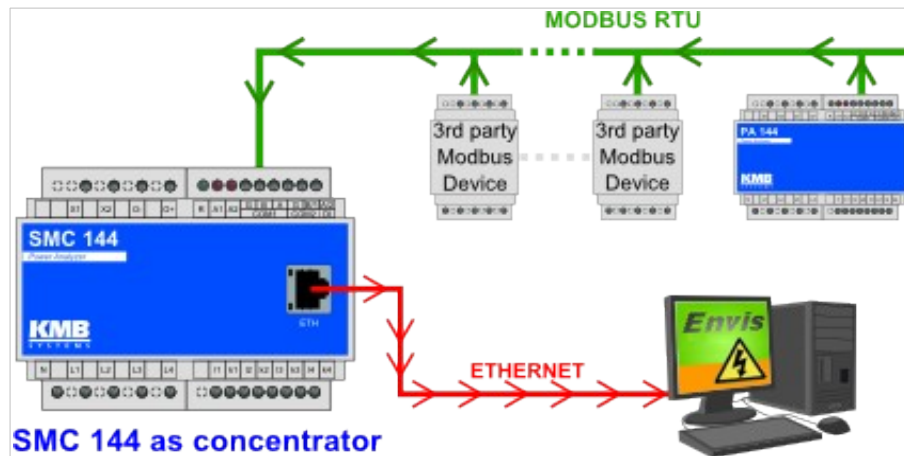

Downloaded values are stored into it's memory including an actual timestamp. Archived readings can be downloaded into a CEA file or to the SQL database with ENVIS.Daq or Online.

Set 2: SML Modbus		MM
U1	238.55 V	
U2	238.57 V	
U3	238.58 V	
I1	0.05 A	
I2	0.05 A	
I3	0.05 A	
EP	183.25 Wh	
Temperature	24.00 °C	
		10:41

The readings can be both viewed on the instrument display (in additional screens in the actual data group) and visualised in the ENVIS program. Users can create graphs, tables, reports and other out of these archive readings.

It's also possible to collect data from electric-, water- and gas-meters, power factor controllers, HVAC, GPS, weather and any other device supporting Modbus.

For details, see the *Modbus Master Firmware Module* application note.

9.5 Ethernet-to-Serial Module

The ES module uses device with multiple communication ports as a remote communication hub between Ethernet and the slave devices connected on one or more RS 485 channels. Data traffic from Ethernet is forwarded to the specific instruments and back in a transparent manner, which simplifies the overall system complexity.

9.6 UDP Push Module

The UDP Push (UP module) pushes a defined interval of values of selected variables through the device's Ethernet interface to the specified server. The data receiver can be an ordinary panel device with a display on the cabinet door to display the current values as well as a publicly available dedicated server. The UP module uses a simple open communication protocol over UDP and does not require any incoming data (queries) on the server side to transmit data.

The UP module also activates user-defined functions for read-out of archive values by Modbus RTU or TCP on selected devices with internal memory.

10. Examples of Connections

**SMY133 U 230 X/5A – Connection with 5A Nominal Output CTs
TN-Network, Direct Star (“3Y”) Connection**

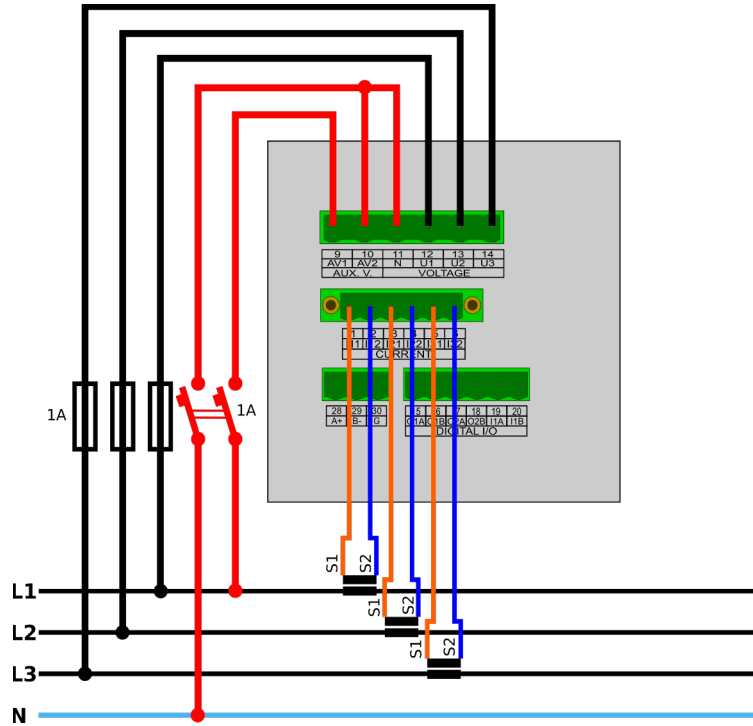

SMY133 U 230 X/333mV – Connection with 333 mV Nominal Output CTs

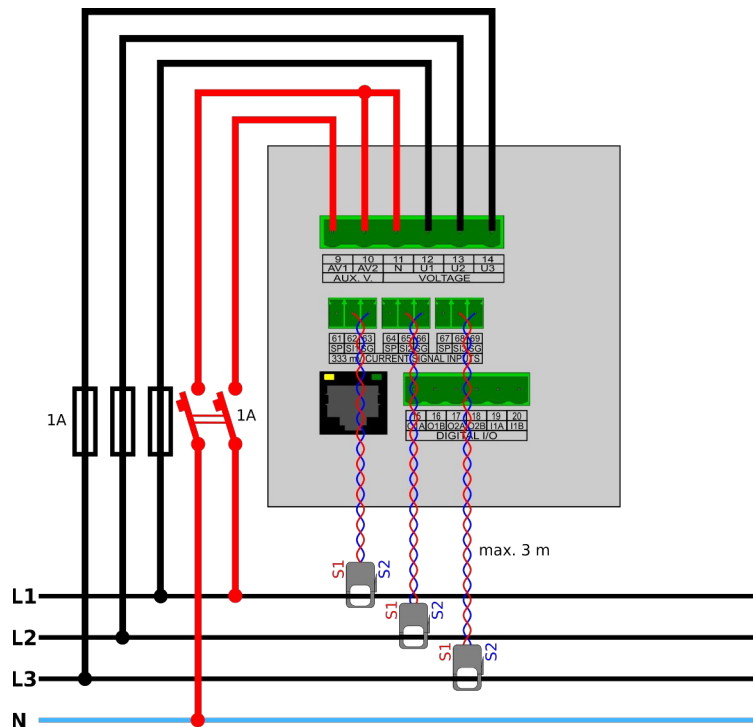

SMY133 U 230 X/333mV – Connection with 333 mV Nominal Output Rogowski Current Sensors Equipped with Embedded Integrators

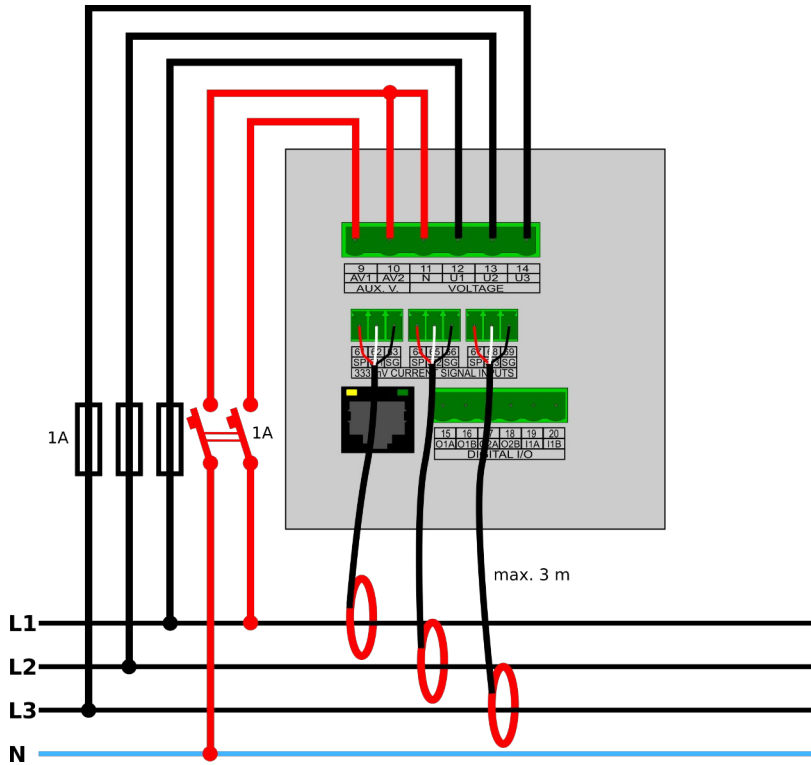

SMY134 S 230 FLEX – Connection with 333 mV Nominal Output Rogowski Current Sensors Equipped with Embedded Integrators

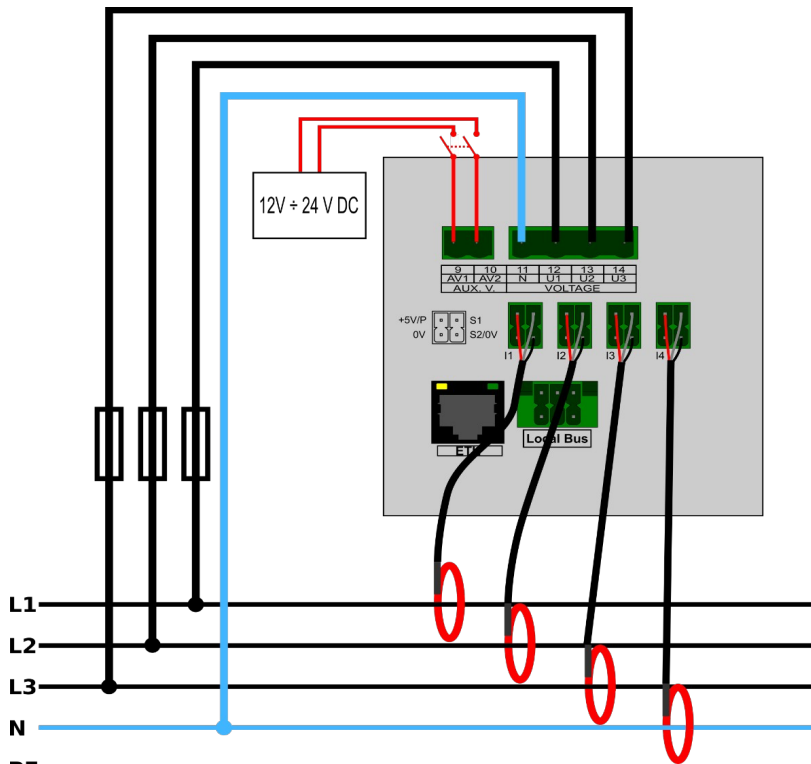

SMY134 U 230 X/5A AA – Connection with 5A Nominal Output CTs & Residual Current Monitoring

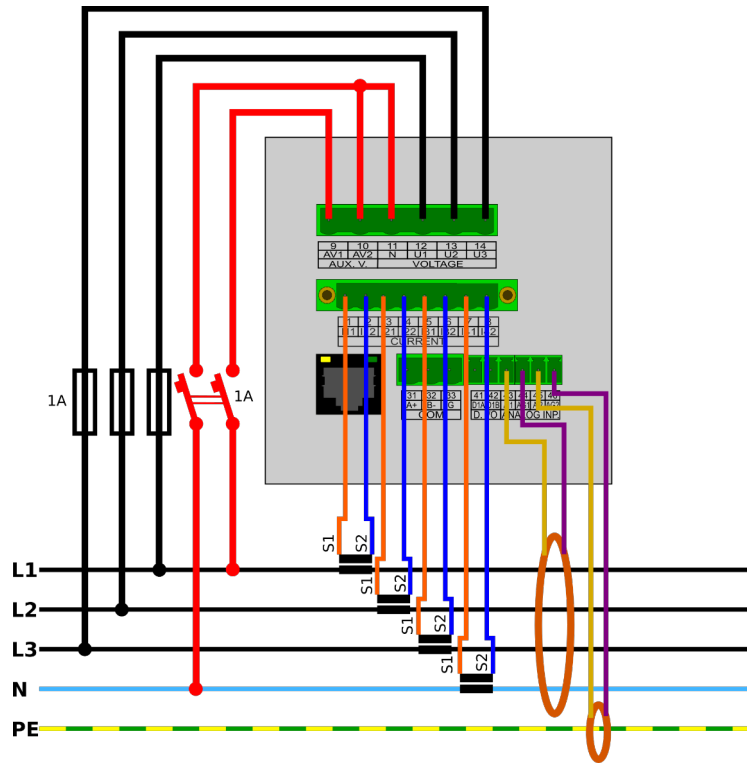

SMP133 S(L) 230 X/5A – Connection with 5A Nominal Output CTs TN-Network, Direct Star ("3Y") Connection

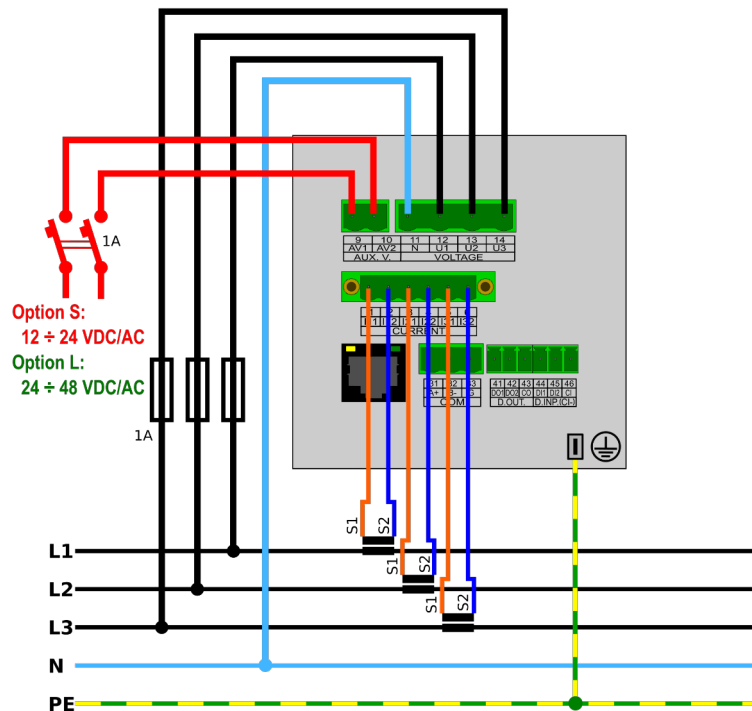

SMY133 ... X/5A – Voltage & Current Connection Examples

*TN Network
Direct Star ("3Y") Connection*

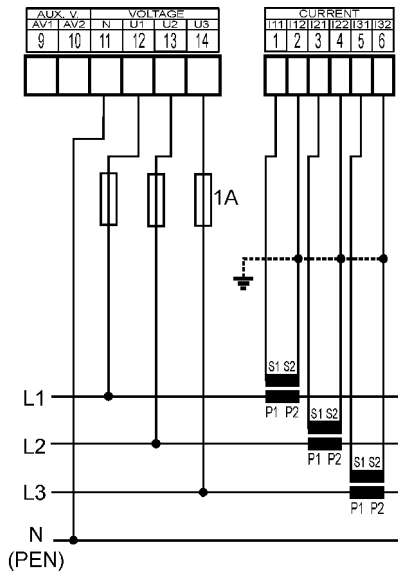

*IT Network
Direct Delta ("3D") Connection*

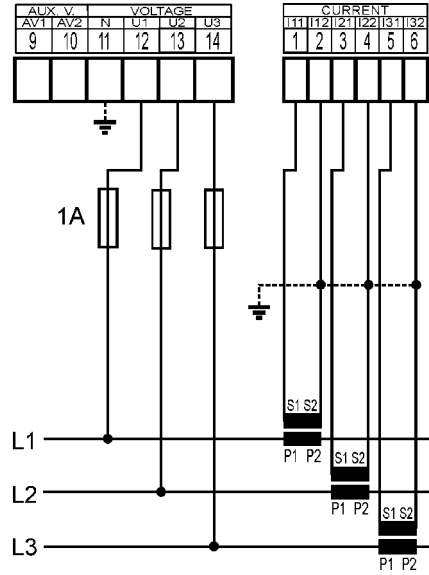

*IT Network
Direct Aron ("3A") Connection*

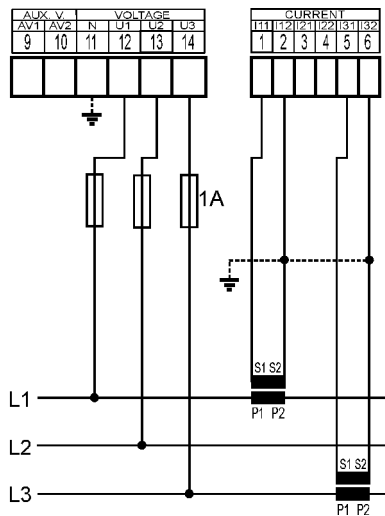

*TN Network
Star ("3Y") Connection via VT*

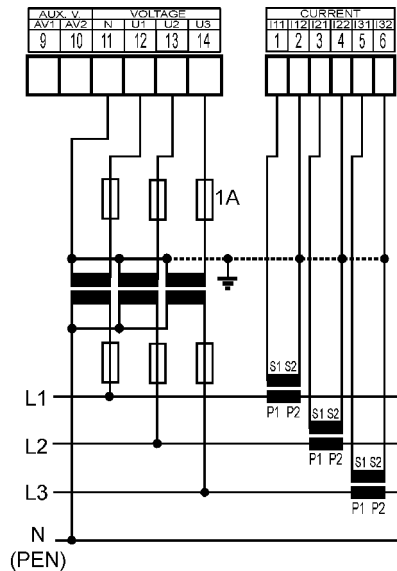

*IT Network
Delta ("3D") Connection via VT
(VT to Line-to-Neutral Primary Voltage)*

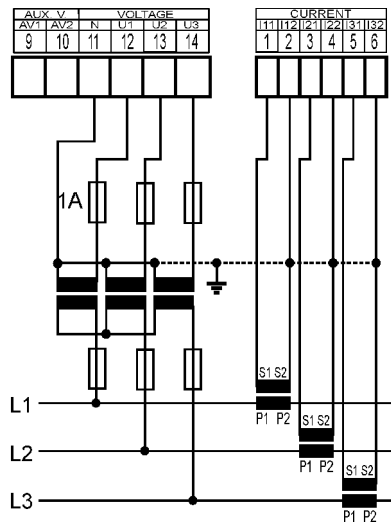

*IT Network
Delta ("3D") Connection via VT
(VT to Line-to-Line Primary Voltage)*

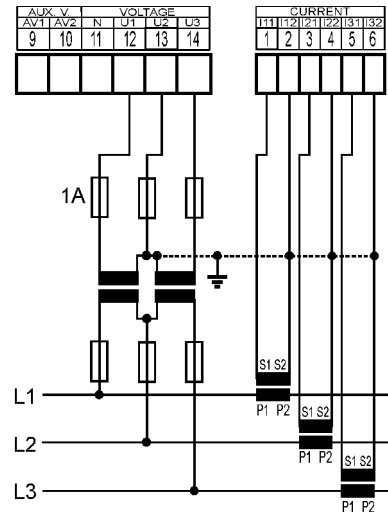

SMY133/134 ... – Power Supply Options

*Line-to-Neutral Voltage
AC Power Supply*

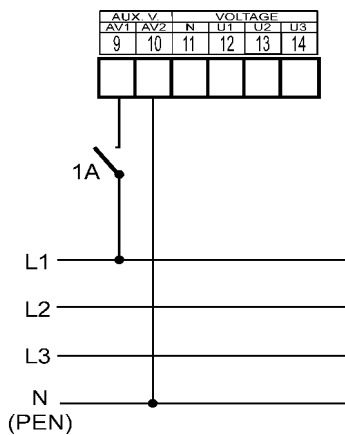

*Line-to-Line Voltage
AC Power Supply*

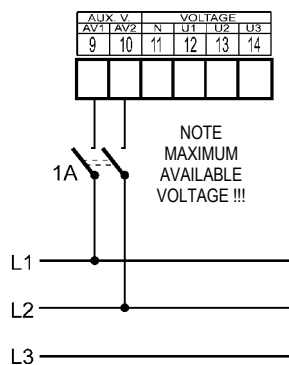

DC Power Supply

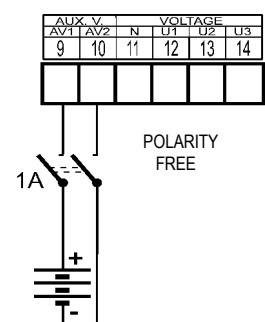

SMY133/134 ... RI – Digital I/O Connection Example

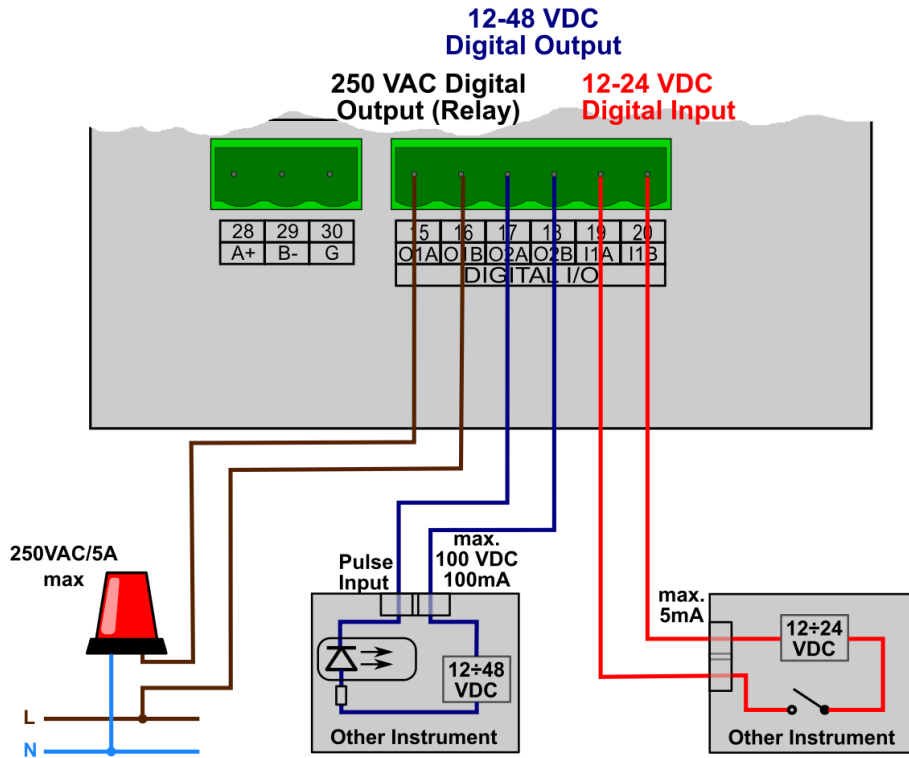

SMY133/134, SMP133 ... V – Digital I/O Connection Example

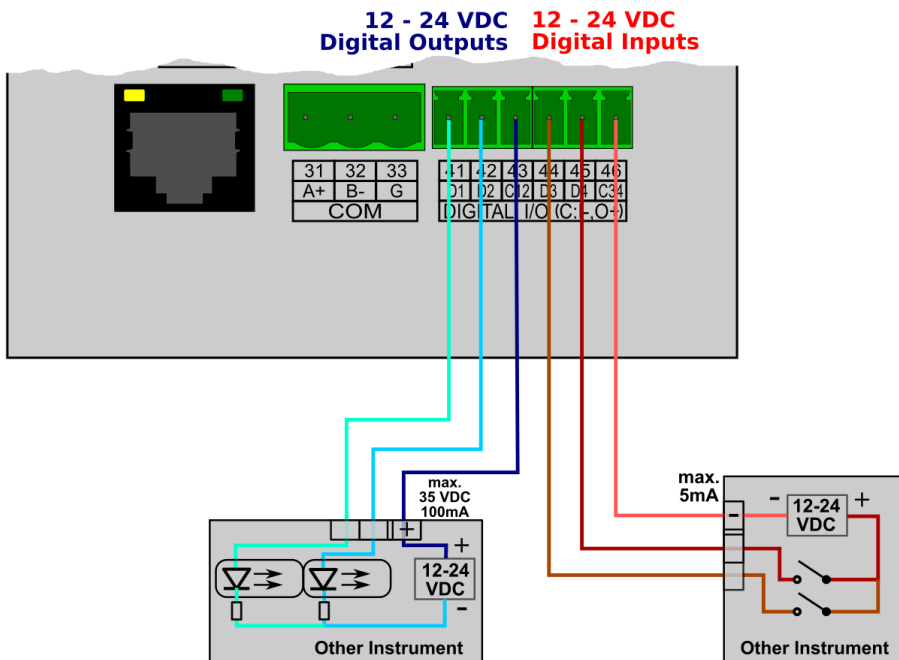

SMY133/134 ... AA – I/O Connection Example 1 x Digital Input, 1 x RCM, 1 x 20 mA Analog Input

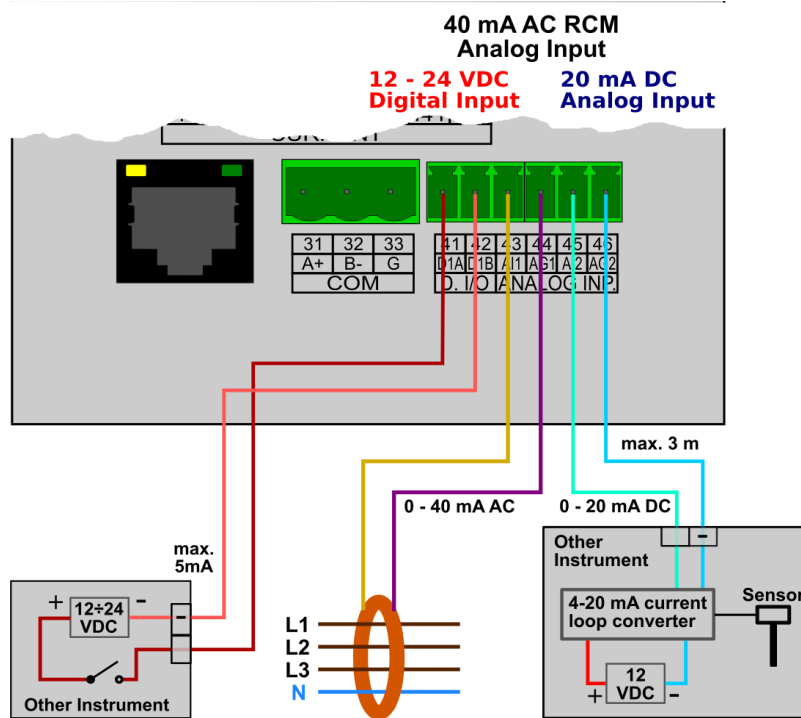

SMY133/134 ... AT – I/O Connection Example 1 x Digital Input, 1 x RCM, 1 x Pt100 Thermometer

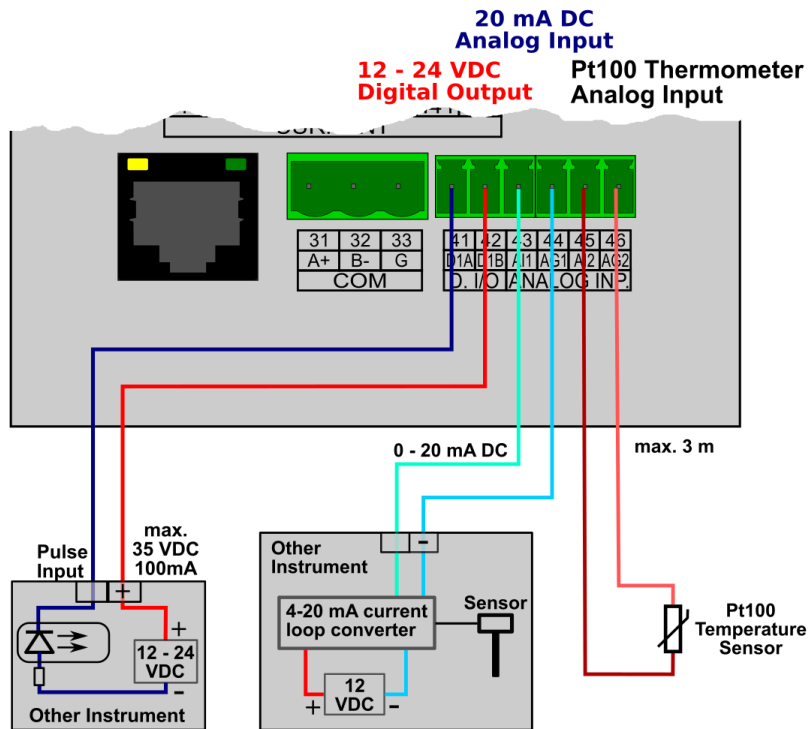

SMY133/134 ... DT – I/O Connection Example Pt100 Thermometer

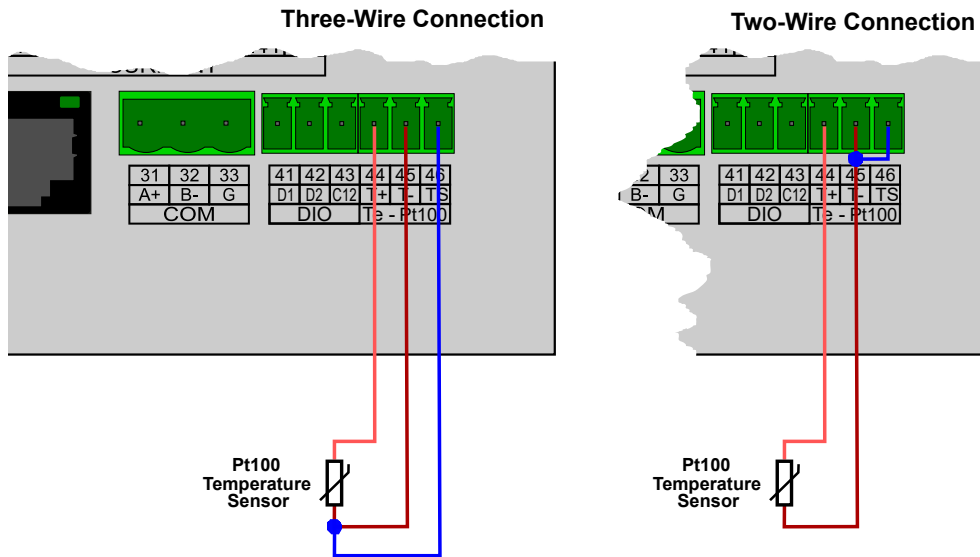

SMY133/134, SMP133 ... 4 – RS-485 Communication Link Connection

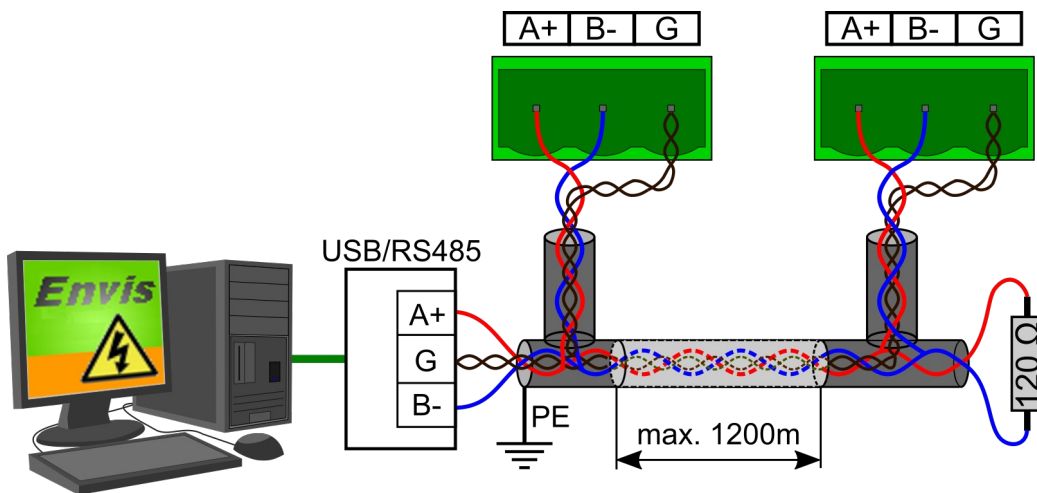

Numbering of Terminals – Measuring & Power Supply Inputs

signal	terminal No.		
AV1	9		
AV2	10		
U1	12		
U2	13		
U3	14		
N	11		
model	“X/5A” / “X/100mA”	“X/333mV”	“FLEX”
I11 / SI1 / I1S1	1	62	I1-3
I12 / SG / I1S2	2	63	I1-4
I21 / SI2 / I2S1	3	65	I2-3
I22 / SG / I2S2	4	66	I2-4
I31 / SI3 / I3S1	5	68	I3-3
I32 / SG / I3S2	6	69	I3-4
I41 / SI4 / I4S1	7	71	I4-3
I42 / SG / I4S2	8	72	I4-4
SP / +5VP1 positive pole of 5V aux. supply for current sensors	-	61, 64, 67,70	1

Numbering of Terminals – I/O

RR/RI/II models		V(W) models		DT models		AA/AT models	
signal	term. No.	signal	term. No.	signal	term. No.	signal	term. No.
O1A	15	D1 (RO1)	41	D1	41	D1A	41
O1B	16	D2 (RO2)	42	D2	42	D1B	42
O2A	17	C12 (CO)	43	C12	43	IΔ11	43
O2B	18	D3 (DI1)	44	T+	44	IΔ12	44
I1A	19	D4 (DI2)	45	T-	45	IΔ21 / T+	45
I1B	20	C34 (CI)	46	TS	46	IΔ22 / T-	46

Numbering of Terminals – Communication

RS – 485 (COM)		M-Bus	
signal	terminal No.	signal	terminal No.
A+ / A+2 *)	28 / 31	M+	28
B- / B-2 *)	29 / 32	M -	29
G / G2 *)	30 / 33	-	-

*) ... valid for models with two RS-485 communication links

11. Manufactured Models and Marking

	SMY 133	U	230	X/5A	RI	E
Instrument Model	SMY 133 = Power analyser, datalogger, 3U, 3I					
Auxiliary Power Supply	U = 110 - 250 V _{AC/DC} S = 12 - 24V _{AC/DC} L = 24 - 48V _{AC/DC}					
Nominal Measuring Voltage	230 = 180 - 250V _{AC} (L-N) / 312 - 433V _{AC} (L-L) 100 = 57,7 - 125V _{AC} (L-N) / 100 - 216V _{AC} (L-L) 400 = 300 - 415V _{AC} (L-N) / 520 - 718V _{AC} (L-L)					
Current Inputs	X/5A = 1 - 5A _{AC} (standard indirect measurement) X/100mA = 100mA _{AC} (indirect measurement) X/333mV = input for sensors with 333mV output					
Digital I/O	N = without I/O RR = 2× relay output + 1× digital input 24V RI = 1× relay output + 1× digital output + 1× digital input 24V II = 2× digital output + 1× digital input 24V V = 4× digital input/output (only with option E4)					
Communication Interface	N = USB, no remote comm. link 4 = USB, RS-485 E = USB, Ethernet E4 = USB, Ethernet, RS-485 (only with option V, 4×IN/OUT)					

	SMY 134	U	230	X/5A	AA	E4
Instrument Model	SMY 134 = Power analyser, datalogger, 3U, 4I					
Auxiliary Power Supply	U = 110 - 250V _{AC/DC} S = 12 - 26V _{DC}					
Nominal Measuring Voltage	230 = 180 - 250V _{AC} (L-N) / 312 - 433V _{AC} (L-L)					
Current Inputs	X/5A = 1 - 5A _{AC} (standard indirect measurement) FLEX = 333mV inputs with 5VDC supply for rogowski coils					
Optional Peripherals	N = no peripherals AA = 2× RCM or 2× input 0/4-20mA, 1× universal input/output AT = 1× RCM or 1× input 0/4-20mA, 1× input for Pt100, 1× universal input/output DT = 1× input for Pt100 (galv. isol.), 2× universal input/output					
Communication Interface	E4 = USB, Ethernet, RS-485 LBE = USB, Ethernet, Localbus (only with Aux. power supply option S)					

	SMP 133	S	230	X/5A	W	E4
Instrument Model	SMP 133 = Power analyser, datalogger, 3U, 3I					
Auxiliary Power Supply	S = 12 ÷ 24V _{AC/DC} , internal backup					
Nominal Measuring Voltage	230 = 180 - 250V _{AC} (L-N) / 312 - 433V _{AC} (L-L)					
Current Inputs	X/5A = 1 - 5A _{AC} (standard indirect measurement)					
Optional Peripherals	W = 2× relay output, 2× digital input					
Communication Interface	E4 = USB, Ethernet, RS-485					

12. Technical Specifications

Function Characteristics according to IEC 61557-12					
Model „230 X/5A“, $U_{NOM} = 230\text{ V}$, $I_{NOM} = 5\text{ A}$					
Symbol	Function	Class		Measuring range	Notes
		SMY133	SMY134 SMP133		
<i>P</i>	total effective power	0.5	0.5	0 ÷ 5400 W	
<i>Q_A, Q_V</i>	total reactive power	1	1	0 ÷ 5400 var	
<i>S_A, S_V</i>	total apparent power	0.5	0.5	0 ÷ 5400 VA	
<i>E_a</i>	total active energy	0.5	0.5	0 ÷ 5400 Wh	
<i>E_{rA}, E_{rV}</i>	total reactive energy	2	2	0 ÷ 5400 varh	
<i>E_{apA}, E_{apV}</i>	total apparent energy	0.5	0.5	0 ÷ 5400 VAh	
<i>f</i>	frequency	0.02	0.02	40 ÷ 70 Hz	
<i>I</i>	phase current	0.5	0.2	0.005 ÷ 6 AAC	
<i>I_N</i>	neutral current measured	–	0.2	–	
<i>I_{Nc}</i>	neutral current calculated	0.5	0.2	0.005 ÷ 18 AAC	
<i>U_{LN}</i>	line-to-neutral voltage	0.5	0.2	40 ÷ 280 VAC	
<i>U_{LL}</i>	line-to-line voltage	0.5	0.2	70 ÷ 480 VAC	
<i>P_{FA}, P_{FV}</i>	power factor	0.5	0.5	0 ÷ 1	
<i>P_{st}, P_{It}</i>	flicker	5	5	0.4 ÷ 10	1, 2)
<i>U_{dip}</i>	voltage dips	0.5	0.5	10 ÷ 230 VAC	2)
<i>U_{swl}</i>	voltage swells	0.5	0.5	230 ÷ 280 VAC	2)
<i>U_{tr}</i>	transients overvoltage	–	–	–	
<i>U_{int}</i>	voltage interruption	1	1	0 ÷ 10 VAC	2)
<i>U_{nba}</i>	voltage unbalance (amp.)	0.5	0.5	0 ÷ 10 %	4)
<i>U_{nb}</i>	voltage unbalance (ph.&.)	0.5	0.5	0 ÷ 10 %	
<i>U_h</i>	voltage harmonics 50 Hz (60 Hz)	2	2	up to 50 th (40 th) order	1)
<i>THD_u</i>	voltage total harm. distortion (rel. to fund.)	2	2	0 ÷ 20 %	1)
<i>THD-R_u</i>	voltage total harm. distortion (rel. to RMS)	2	2	0 ÷ 20 %	1, 4)
<i>I_h</i>	current harmonics 50 Hz (60 Hz)	2	2	up to 50 th (40 th) order	1)
<i>THD_i</i>	current total harm. distortion (rel. to fund.)	2	2	0 ÷ 200 %	1)
<i>THD-R_i</i>	voltage total harm. distortion (rel. to RMS)	2	2	0 ÷ 200 %	1, 4)
<i>M_{sv}</i>	mains signalling voltage	2	2	0 ÷ 46 VAC $f_{Msv} : 100 \div 3000\text{ Hz}$	1, 3)

Notes : 1) ...according to IEC 61000-4-7 ed.2

2) ... with optional firmware module „PQ S“

3) ... with optional firmware module „RCS“

4) ... value available via communication link only, not displayed

Function Characteristics according to IEC 61557-12					
UNOM = 100 / 230 / 400 V for model "100" / "230" / "400"					
Model „X/5A“, INOM = 5 A					
Symbol	Function	Class		Measuring range	Notes
		SMY133	SMY134 SMP133		
P	total effective power	0.5	0.5	0 ÷ (21.6 * UNOM) W	
QA, QV	total reactive power	1	1	0 ÷ (21.6 * UNOM) var	
SA, SV	total apparent power	0.5	0.5	0 ÷ (21.6 * UNOM) VA	
Ea	total active energy	0.5	0.5	0 ÷ (21.6 * UNOM) Wh	
ErA, ErV	total reactive energy	2	2	0 ÷ (21.6 * UNOM) varh	
EapA, EapV	total apparent energy	0.5	0.5	0 ÷ (21.6 * UNOM) VAh	
f	frequency	0.02	0.02	40 ÷ 70 Hz	
I	phase current	0.5	0.2	0.005 ÷ 6 AAC	
IN	neutral current measured	–	0.2	–	
INc	neutral current calculated	0.5	0.2	0.005 ÷ 18 AAC	
ULN	line-to-neutral voltage	0.5	0.2	0.2 ÷ 1.2 * UNOM	
ULL	line-to-line voltage	0.5	0.2	0.2 ÷ 1.2 * UNOM * √3	
PFA, PFV	power factor	0.5	0.5	0 ÷ 1	
Pst, Pit	flicker	5	5	0.4 ÷ 10	1, 2)
Udip	voltage dips	0.5	0.5	0.05 ÷ 1 * UNOM	2)
Uswl	voltage swells	0.5	0.5	1 ÷ 1.2 * UNOM	2)
Utr	transients overvoltage	–	–	–	
Uint	voltage interruption	1	1	0 ÷ 0.05 * UNOM	2)
Unba	voltage unbalance (amp.)	0.5	0.5	0 ÷ 10 %	4)
Unb	voltage unbalance (ph.&.)	0.5	0.5	0 ÷ 10 %	
Uh	voltage harmonics 50 Hz (60 Hz)	2	2	up to 50 th (40 th) order	1)
THDu	voltage total harm. distortion (rel. to fund.)	2	2	0 ÷ 20 %	1)
THD-Ru	voltage total harm. distortion (rel. to RMS)	2	2	0 ÷ 20 %	1, 4)
Ih	current harmonics 50 Hz (60 Hz)	2	2	up to 50 th (40 th) order	1)
THDi	current total harm. distortion (rel. to fund.)	2	2	0 ÷ 200 %	1)
THD-Ri	voltage total harm. distortion (rel. to RMS)	2	2	0 ÷ 200 %	1, 4)
Msv	mains signalling voltage	2	2	0 ÷ 0.2 * UNOM fMsv : 100 ÷ 3000 Hz	1, 3)

Notes : 1) ...according to IEC 61000-4-7 ed.2

2) ... with optional firmware module „PQ S“

3) ... with optional firmware module „RCS“

4) ... value available via communication link only, not displayed

Function Characteristics according to IEC 61557-12					
UNOM = 100 / 230 / 400 V for model "100" / "230" / "400"					
Model „X/100mA“, INOM = 0.1 A					
Symbol	Function	Class		Measuring range	Notes
		SMY133	SMY134 SMP133		
P	total effective power	0.5	0.5	$0 \div (0.43 * U_{NOM})$ W	
QA, QV	total reactive power	1	1	$0 \div (0.43 * U_{NOM})$ var	
SA, SV	total apparent power	0.5	0.5	$0 \div (0.43 * U_{NOM})$ VA	
Ea	total active energy	0.5	0.5	$0 \div (0.43 * U_{NOM})$ Wh	
ErA, ErV	total reactive energy	2	2	$0 \div (0.43 * U_{NOM})$ varh	
EapA, EapV	total apparent energy	0.5	0.5	$0 \div (0.43 * U_{NOM})$ VAh	
f	frequency	0.02	0.02	40 ÷ 70 Hz	
I	phase current	0.5	0.2	0.001 ÷ 0.12 AAC	
IN	neutral current measured	–	0.2	–	
INc	neutral current calculated	0.5	0.2	0.001 ÷ 0.36 AAC	
ULN	line-to-neutral voltage	0.5	0.2	$0.2 \div 1.2 * U_{NOM}$	
ULL	line-to-line voltage	0.5	0.2	$0.2 \div 1.2 * U_{NOM} * \sqrt{3}$	
PFA, PFV	power factor	0.5	0.5	0 ÷ 1	
Pst, PIt	flicker	5	5	0.4 ÷ 10	1, 2)
Udip	voltage dips	0.5	0.5	$0.05 \div 1 * U_{NOM}$	2)
Uswl	voltage swells	0.5	0.5	$1 \div 1.2 * U_{NOM}$	2)
Utr	transients overvoltage	–	–	–	
Uint	voltage interruption	1	1	$0 \div 0.05 * U_{NOM}$	2)
Unba	voltage unbalance (amp.)	0.5	0.5	0 ÷ 10 %	4)
Unb	voltage unbalance (ph.&.)	0.5	0.5	0 ÷ 10 %	
Uh	voltage harmonics 50 Hz (60 Hz)	2	2	up to 50 th (40 th) order	1)
THDu	voltage total harm. distortion (rel. to fund.)	2	2	0 ÷ 20 %	1)
THD-Ru	voltage total harm. distortion (rel. to RMS)	2	2	0 ÷ 20 %	1, 4)
Ih	current harmonics 50 Hz (60 Hz)	2	2	up to 50 th (40 th) order	1)
THDi	current total harm. distortion (rel. to fund.)	2	2	0 ÷ 200 %	1)
THD-Ri	voltage total harm. distortion (rel. to RMS)	2	2	0 ÷ 200 %	1,4)
Msv	mains signalling voltage	2	2	$0 \div 0.2 * U_{NOM}$ fMsv : 100 ÷ 3000 Hz	1, 3)

Notes : 1) ...according to IEC 61000-4-7 ed.2

2) ... with optional firmware module „PQ S“

3) ... with optional firmware module „RCS“

4) ... value available via communication link only, not displayed

Instrument Characteristics according to IEC 61557-12	
power quality assessment function	PQI-S
classification according to par. 4.3 direct voltage connection voltage connection via VT	SD SS
temperature according to par. 4.5.2.2	K55
humidity + altitude according to par. 4.5.2.3	< 95 % - noncondensation conditions < 2000 m
active power/energy function performance class	0.5

Function characteristics according to IEC 61000-4-30 ed.3				
Function	Class	Uncertainty	Measuring range	Notes
frequency	A	± 10 mHz	40 ÷ 70 Hz	
magnitude if supply	S	± 0.1 % U_{din}	20 ÷ 120 % U_{din}	
flicker	S	± 5 % of rdg or $\pm 0,05$	0.4 ÷ 10	2, 4)
dips and swells	S	± 0.5 % U_{din} , ± 1 cycle	5 ÷ 120 % U_{din}	2)
interruptions	S	± 1 cycle	unlimited	2)
unbalance	S	± 0.3 %	0.5 ÷ 10 %	
voltage harmonics & interharmonics	S	twice the levels of class II acc. IEC 61000-4-7 ed.2	10 ÷ 100 % of class 3, acc. to IEC 61000-2-4 ed.2, up to 50 th order	1)
mains signalling voltage	S	twice the levels of class II acc. IEC 61000-4-7 ed.2	0 ÷ 20 % U_{din} f_{Msv} : 100 ÷ 3000 Hz	1, 3)

Notes : 1) ...according to IEC 61000-4-7 ed.2

2) ... with optional firmware module „PQ S“

3) ... with optional firmware module „RCS“

4) ... class F3 according to IEC 61000-4-15 ed. 2.0

Measured Quantities – Voltage *)			
Frequency			
f_{NOM} – nominal frequency	50 / 60 Hz		
measuring range	40 ÷ 70 Hz		
measuring uncertainty	± 10 mHz		
Voltage			
model	„100“	„230“	„400“
U_{NOM} (U_{DIN}) – rated voltage (phase-to-neutral, $U_{\text{L-N}}$)	57.7 ÷ 125 VAC	180 ÷ 250 VAC	300 ÷ 415 VAC
crest factor at U_{NOM}	2.1		
measuring range $U_{\text{L-N}}$	3 ÷ 190 VAC	6 ÷ 375 VAC	10 ÷ 625 VAC
measuring range $U_{\text{L-L}}$	5 ÷ 330 VAC	8 ÷ 660 VAC	20 ÷ 1090 VAC
measuring uncertainty ($t_{\text{A}}=23\pm 2^{\circ}\text{C}$)	+/- 0.05 % of rdg +/- 0.02 % of rng		
temperature drift	+/- 0.03 % of rdg +/- 0.01 % of rng / 10 °C		
measurement category	150V CAT IV	SMY: 300V CAT III SMP: 300V CAT IV	300V CAT III 600V CAT II
permanent overload	300 VAC	600 VAC	1000 VAC
peak overload ($U_{\text{L-N}}$ / 1 sec.)	600 VAC	1200 VAC	2000 VAC
burden power, impedance	< 0.013 VA $R_i = 1.8 \text{ M}\Omega$	< 0.025 VA $R_i = 3.6 \text{ M}\Omega$	< 0.05 VA $R_i = 6 \text{ M}\Omega$
Voltage Unbalance			
measuring range	0 ÷ 10 %		
measuring uncertainty	± 0.3		
Harmonics & Interharmonics (up to 50th order, or 40th order @ 60 Hz)			
reference conditions	other harmonics up to 200 % of class 3 acc. to IEC 61000–2-4 ed.2		
measuring range	10 ÷ 100 % of class 3 acc. to IEC 61000–2-4 ed.2		
measuring uncertainty	twice the levels of class II acc. to IEC 61000–4-7 ed.2		
THDU			
measuring range	0 ÷ 20 %		
measuring uncertainty	± 0.5		

Note *) : The quantities and their measurement uncertainties are valid for $f_{\text{NOM}} = 50/60$ Hz. For $f_{\text{NOM}} = \text{DC} \div 500$ Hz ("The Fixscan" mode), see separate table below.

Measured Quantities – Current *)			
model	„X/5A“	„X/100mA“	„X/333mV“ / „FLEX“
I_{NOM} (I _B) – rated current	1 / 5 AAC	0.1 AAC	I @ 333mV
crest factor at I_{NOM}	SMY : 2.0 SMP : 17	5.5	2.1
measuring range SMY: SMP:	0.005 ÷ 7 AAC 0.005 ÷ 60 AAC	0.001 ÷ 0.39 AAC 0.001 ÷ 3.5 AAC	0.002 ÷ 0.5 VAC
meas. uncertainty ($t_A=23\pm 2^\circ\text{C}$)	+/- 0.05 % of rdg +/- 0.02 % of rng		
temperature drift	+/- 0.03 % of rdg +/- 0.01 % of rng / 10 °C		
measurement category	SMY: 150V CAT III SMP: 150V CAT IV	150V CAT III	undefined
permanent overload	7.5 AAC	1 AAC	5 VAC
peak overload - for 1 second, max. repetition frequency > 5 minutes	70 AAC	10 AAC	15 VAC
burden power (impedance)	< 0.5 VA (Ri < 10 mΩ)	< 0.01 VA (Ri < 40 mΩ)	< 3 uVA (Ri > 100kΩ)
Current Unbalance			
measuring range	0 ÷ 100 %		
measuring uncertainty	± 1 % of rdg or ± 0.5		
Harmonics & Interharmonics (up to 50th order, or 40th order @ 60 Hz)			
reference conditions	other harm. up to 1000 % of class 3 acc. to IEC 61000–2-4 ed.2		
measuring range	500 % of class 3 acc. to IEC 61000–2-4 ed.2		
measuring uncertainty	I _h ≤ 10% I _{NOM} : ± 1% I _{NOM} I _h > 10% I _{NOM} : ± 1% of rdg		
THDI			
measuring range	0 ÷ 200 %		
measuring uncertainty	THDI ≤ 100% : ± 0.6 THDI > 100% : ± 0.6 % of rdg		

Note *) : The quantities and their measurement uncertainties are valid for $f_{NOM} = 50/60$ Hz. For $f_{NOM} = DC \div 500$ Hz ("The Fixscan" mode), see separate table below.

Measured Quantities – Power, Power Factor, Energy *)	
Active / Reactive Power, Power Factor (PF), cos φ (P_{NOM} = U_{NOM} x I_{NOM})	
reference conditions "A" : ambient temperature (t _A) U, I for active power, PF, cos φ for reactive power	23 ± 2 °C U = 80 ÷ 120 % U _{NOM} , I = 1 ÷ 120 % I _{NOM} PF = 1.00 PF = 0.00
act. / react. power uncertainty	± 0.5 % of rdg ± 0.005 % P _{NOM}
PF & cos φ uncertainty	± 0.005
reference conditions "B" : ambient temperature (t _A) U, I for active power, PF, cos φ for reactive power	23 ± 2 °C U = 80 ÷ 120 % U _{NOM} , I = 1 ÷ 120 % I _{NOM} PF ≤ 0.87 PF ≤ 0.87
act. / react. power uncertainty	± 1 % of rdg ± 0.01 % P _{NOM}
PF & cos φ uncertainty	± 0.005
temperature drift of powers	+/- 0.05 % of rdg +/- 0.02 % P _{NOM} / 10 °C
Energy	
measuring range	corresponds to U & I measuring ranges 4 quadrant energy counters for both active and reactive energies
active energy uncertainty	class 0.5S acc. to EN 62053 – 22
reactive energy uncertainty	class 1S acc. to EN 62053 – 24

Note *) : The quantities and their measurement uncertainties are valid for f_{NOM} = 50/60 Hz. For f_{NOM} = DC ÷ 500 Hz ("The Fixscan" mode), see separate table below.

„FIXSCAN“ Mode - Measuring Uncertainties	
f_{NOM} set to „DC-500“	
Frequency Range : 350 ÷ 450 Hz	
Frequency	
measuring uncertainty	± 0.1 Hz
Voltage	
measuring uncertainty	+/- 0.2 % of rdg +/- 0.1 % of rng
Current	
measuring uncertainty	+/- 0.2 % of rdg +/- 0.1 % of rng
Active / Reactive Power, Power Factor (PF), cos φ (P_{NOM} = U_{NOM} x I_{NOM})	
reference conditions "A" : U, I for active power, PF, cos φ for reactive power	U = 80 ÷ 120 % U _{NOM} , I = 1 ÷ 120 % I _{NOM} PF = 1.00 PF = 0.00
act. / react. power uncertainty	± 0.5 % of rdg ± 0.01 % P _{NOM}
PF & cos φ uncertainty	± 0.01
reference conditions "B" : U, I for active power, PF, cos φ for reactive power	U = 80 ÷ 120 % U _{NOM} , I = 1 ÷ 120 % I _{NOM} PF ≥ 0.5 PF ≤ 0.87
act. / react. power uncertainty	± 2 % of rdg ± 0.1 % P _{NOM}
PF & cos φ uncertainty	± 0.02

Instrument Auxiliary Power Supply Voltage			
model	„U“	„L“	„S“
rated (nominal) auxiliary voltage range	110 ÷ 250 V _{AC}	24 ÷ 60 V _{DC}	12 ÷ 30 V _{DC}
aux. voltage range AC: f=40÷100 Hz; DC:	100 ÷ 275 V _{AC} 90 ÷ 350 V _{DC}	20 ÷ 50 V _{AC} 20 ÷ 75 V _{DC}	10 ÷ 26 V _{AC} 10 ÷ 36 V _{DC}
power	8 VA / 4 W		
overvoltage cat.	III		SMY: III SMP: IV
pollution degree	2		
maximum operating altitude	2000 m		
connection	isolated, polarity free		
power outage backup (SMP 133 only) technology backup time	supercapacitors; instrument measuring core backup only > 3 sec after being powered from external power supply for > 5 min > 1 sec after being powered from external power supply for > 1.5 min		

„X/333mV“ / „FLEX“ Instrument Model Auxiliary Voltage for Current Sensors	
connection	non-isolated (connected with the instrument internal circuitry)
output voltage	+5 V _{DC} ± 5 %
maximum permanent load	60 mA _{DC}
short-circuit current, max. duration	approx. 100 mA _{DC} , 5 seconds

Measured Quantities - Temperature		
T_i - (internal sensor, measured value affected by the instrument power dissipation)		
measuring range	- 40 ÷ 80 °C	
measurement uncertainty	± 2 °C	
T_E – External Pt100 Temperature Sensor Input („DT“ and „AT“ models only)		
measuring range	- 50 ÷ 150 °	
measurement uncertainty	± 2 °C	
model	“DT”	“AT”
notes	<ul style="list-style-type: none"> - External temperature input is isolated from instrument internal circuitry - Three-wire or two-wire connection possible 	<ul style="list-style-type: none"> - External temperature input is isolated neither from instrument internal circuitry nor from residual current input - The terminals T- and IΔ12 are connected internally, do not connect signals of different potential ! - Maximum length of connection cable is 3 meters ! Otherwise, EMC-immunity of the instrument can be degraded.



Residual Current / Analog Inputs		
mode of operation	RCM	20 mA DC
measuring range	0.01 - 40 mA _{AC}	0.02 - 22 mA _{DC}
residual operating current I _{Δn} setup range	0.1 - 30 mA _{AC}	-
intrinsic uncertainty (t _A =23±2°C)	+/- 0.1 % of rdg + +/- 0.02 % of rng	
temperature drift	+/- 0.03 % of rdg + +/- 0.01 % of rng / 10°C	
permanent overload	1 A _{AC}	
peak overload	6 A _{AC} / 200 ms, repetition delay > 5 seconds 60 A _{AC} / 20 ms, repetition delay > 1 minute	
burden power (impedance)	< 0.007 VA (R _i = 4 Ω)	
notes	<p>- Measuring inputs isolated neither from instrument internal circuitry nor mutually not from external temperature input</p> <p>- The terminals I_{Δ12} and I_{Δ12} (or T-) are connected internally, do not connect signals of different potential !</p> <p>- Maximum length of connection cable is 3 meters ! Otherwise, EMC-immunity of the instrument can be degraded.</p> <p>RCM mode :</p> <p>- Inputs designed for indirect connection only – suitable residual current transformer (RCT) must be used</p> <p>- Insulation of the RCT must fulfil IEC61010-1 requirements for the CATIII double insulation for the mains voltage present</p> <p>- Alternating and pulsating direct residual currents measurement according the A-type RCM specification as defined in the IEC 62020 standard</p> <p>- No directional sensitivity of the residual currents evaluated</p>	

Residual Current Transformer Examples							
Manu facturer	Type	I _n [A]	Window Size [mm] Diameter or x/y or Length	RCT_ratio / 20 mA _{DC}	I _{Δn} [A]	R _{RCM} MAX [Ω]	Notes
Bender	W	n.s. *)	D 20 - 210	600 / 1	10	180	fixed core
Bender	WS	n.s. *)	20x30 - 80x120	600 / 1	10	180	split core
Bender	WF	n.s. *)	L 170 - 1800	600 / 1	0.1 - 20	68	Rogowski-type, split core
MBS	DACT	n.s. *)	D 20 - 120	600 / 1	0.02 - 20	180	fixed core
Doepke	DCTRA	200-300	D 35 - 70	20 mA _{DC}	0.3	300	fixed core, 20 mA _{DC} current loop output
IME	TD	65-630	D 28 - 310	700 / 1	0.03 – 1 (I _{Δn} min.)	n.s. *)	fixed core
J&D	BCT	100-600	D 30 - 80	127 / 1	10	10	fixed core

n.s. *). not specified

Digital Outputs & Digital Inputs			
„R“-Type Outputs (relay)			
model / outputs	“RR / RI” / “R”-outputs		“W” / RO1-2
type	relay, N.O. contact		
load rating	250 V _{AC} / 30 V _{DC} , 4 A		30 V _{DC} , 4 A
„D“-Type Outputs (solid state, opto-MOS)			
model / outputs	“RI / II” / “I”-outputs	“V / DT / AA / AT” / DO1-4	“W”
typ	Opto-MOS, bipolar	Opto-MOS, unipolar	-
load rating	60 V _{AC} / 100 V _{DC} , 100 mA	35 V _{DC} , 100 mA	-
dynamic param. (pulse output) : - pulse duration - gap duration - maximum frequency	S0 - compatible 50 ms ≥ 50 ms 10 Hz		-
Digital Inputs			
model	“RR / RI / II”	“V / DT / AA / AT”	“W” / DI3-4
type	optoisolated, bipolar	optoisolated, unipolar	optoisolated, bipolar
maximum voltage	100 V _{DC} // 60 V _{AC}	35 V _{DC}	
voltage for “logical “ 0 / 1	< 3 V _{DC} / > 10 V _{DC}		< 3 V _{DC} / > 10 V _{DC}
input current	1 mA @ 10V / 5 mA @ 24V / 10 mA @ 48V	3 mA @ 10V / 13 mA @ 24V / 20 mA @ 35V	
dynamic parameters *) : - pulse/gap duration - maximum frequency	≥ 50 / 50 ms 10 Hz	≥ 0.5 / 0.5 ms 1 kHz	

Note *) : Limit that correspond to the instrument hardware. Real values depend on the firmware filter adjustment - see the chapter *Digital Input Filter*.

Other Specifications	
operational temperature :	- 20 to 60°C
storage temperature	- 40 to 80°C
operational and storage humidity	< 95 % - non-condensable environment
EMC – immunity	EN 61000 – 4 - 2 (4kV / 8kV) EN 61000 – 4 - 3 (10 V/m up to 1 GHz) EN 61000 – 4 - 4 (2 kV) EN 61000 – 4 - 5 (2 kV) EN 61000 – 4 - 6 (3 V) EN 61000 – 4 - 11 (5 periods)
EMC – emissions	EN 55011, class A EN 55032, class A (not for home use)
protection class (IEC 61140)	SMY : II -  SMP : I - 
RTC accuracy backup battery capacity	+/- 2 seconds per day > 5 years (without supply voltage applied)
communication ports	USB 2.0 optional RS-485(2.4÷460 kBd), Ethernet 100 Base-T, M-Bus
communication protocols	KMB, Ethernet to RS-485 gateway (optional FW-module), Modbus RTU and TCP, Modbus Master (optional FW-module), WEB server, JSON, DHCP, SNTP
sampling frequency 50 Hz (60 Hz)	SMY 133 : 6.4 kHz (5.76 kHz) SMY133 G2, SMY134, SMP133 : 25.6 kHz (23.04 kHz)
display	colour TFT-LCD, 3.5" diagonal, 320x240 pixels
protection class (IEC 60529) front panel back panel	IP 40 (IP 54 with cover sheeting) IP 20
dimensions front panel built-in depth installation cutout	96 x 96 mm 80 mm 92 ⁺¹ x 92 ⁺¹ mm
mass	max. 0.3 kg

13. Maintenance, Service

Instruments do not require any maintenance in their operation. For reliable operation it is only necessary to meet the operating conditions specified and not expose the instrument to violent handling and contact with water or chemicals which could cause mechanical damage.

Built-in CR2450 lithium cell backups memory and real time circuit for more than 5 years without power supply, at average temperature 20°C and load current in the instrument less than 10 µA. If the cell is empty, it is necessary to ship the instrument to the manufacturer for battery replacement.

In the case of failure or a breakdown of the product, you should contact the supplier at their address:

Supplier :

Manufacturer : KMB systems, s.r.o.
Dr. M. Horákové 559
460 06 LIBEREC 7
Czech Republic
Phone+420 485 130 314
Fax +420 482 736 896
E-mail: kmb@kmb.cz
Website: www.kmbsystems.eu

The product must be in proper packaging to prevent damage during transit. A description of the problem or its symptoms must be delivered together with the product.

If a warranty repair is claimed, the warranty certificate must be sent in. In case of an out-of-warranty repair you have to enclose an order for the repair.

Warranty Certificate

Warranty period of 24 months from the date of purchase is provided for the instrument, however, no longer than 30 months from the day of dispatch from the manufacturer. Problems in the warranty period, provably because of faulty workmanship, design or inconvenient material, will be repaired free of charge by the manufacturer or an authorized servicing organization.

The warranty ceases even within the warranty period if the user makes unauthorized modifications or changes to the instrument, connects it to out-of-range quantities, if the instrument is damaged due to ineligible or improper handling by the user, or when it is operated in contradiction with the technical specifications presented.

Type of product: Serial number.....
Date of dispatch: Final quality inspection:
Manufacturer's seal:

Date of purchase: Supplier's seal: